



10623 Roselle Street, San Diego, CA 92121 • (858) 550-9559 • Fax (858) 550-7322
contactus@accesio.com • www.accesio.com

MODEL USB-IIRO4-2SM

USER MANUAL

MUSB-IIRO4-2SM.A1o

Notice

The information in this document is provided for reference only. ACCES does not assume any liability arising out of the application or use of the information or products described herein. This document may contain or reference information and products protected by copyrights or patents and does not convey any license under the patent rights of ACCES, nor the rights of others.

IBM PC, PC/XT, and PC/AT are registered trademarks of the International Business Machines Corporation.

Printed in USA. Copyright 2006 by ACCES I/O Products Inc, 10623 Roselle Street, San Diego, CA 92121. All rights reserved.

WARNING!!

ALWAYS CONNECT AND DISCONNECT YOUR FIELD CABLING WITH THE COMPUTER POWER OFF. ALWAYS TURN COMPUTER POWER OFF BEFORE INSTALLING A CARD. CONNECTING AND DISCONNECTING CABLES, OR INSTALLING CARDS INTO A SYSTEM WITH THE COMPUTER OR FIELD POWER ON MAY CAUSE DAMAGE TO THE I/O CARD AND WILL VOID ALL WARRANTIES, IMPLIED OR EXPRESSED.

Warranty

Prior to shipment, ACCES equipment is thoroughly inspected and tested to applicable specifications. However, should equipment failure occur, ACCES assures its customers that prompt service and support will be available. All equipment originally manufactured by ACCES which is found to be defective will be repaired or replaced subject to the following considerations.

Terms and Conditions

If a unit is suspected of failure, contact ACCES' Customer Service department. Be prepared to give the unit model number, serial number, and a description of the failure symptom(s). We may suggest some simple tests to confirm the failure. We will assign a Return Material Authorization (RMA) number which must appear on the outer label of the return package. All units/components should be properly packed for handling and returned with freight prepaid to the ACCES designated Service Center, and will be returned to the customer's/user's site freight prepaid and invoiced.

Coverage

First Three Years: Returned unit/part will be repaired and/or replaced at ACCES option with no charge for labor or parts not excluded by warranty. Warranty commences with equipment shipment.

Following Years: Throughout your equipment's lifetime, ACCES stands ready to provide on-site or in-plant service at reasonable rates similar to those of other manufacturers in the industry.

Equipment Not Manufactured by ACCES

Equipment provided but not manufactured by ACCES is warranted and will be repaired according to the terms and conditions of the respective equipment manufacturer's warranty.

General

Under this Warranty, liability of ACCES is limited to replacing, repairing or issuing credit (at ACCES discretion) for any products which are proved to be defective during the warranty period. In no case is ACCES liable for consequential or special damage arriving from use or misuse of our product. The customer is responsible for all charges caused by modifications or additions to ACCES equipment not approved in writing by ACCES or, if in ACCES opinion the equipment has been subjected to abnormal use. "Abnormal use" for purposes of this warranty is defined as any use to which the equipment is exposed other than that use specified or intended as evidenced by purchase or sales representation. Other than the above, no other warranty, expressed or implied, shall apply to any and all such equipment furnished or sold by ACCES.

TABLE OF CONTENTS

- Chapter 1: Introduction5
 - Communication Mode6
 - Figure 1-1: Block Diagram.....9
- Chapter 2: Installation10
 - Hardware Installation.....10
- Chapter 3: Option Selection.....11
 - Figure 3-1: Option Selection Map.....12
- Chapter 4: Address Selection13
- Chapter 5: Programming14
- Chapter 6: Connector Pin Assignments15
 - Table 6-1: Enclosure Mounted DB25 Pin-out and 26 Pin Header Translation15
 - Table 6-2: Serial Connector Pin Assignments16

Chapter 1: Introduction

This unit is a USB multifunction device, incorporating a USB 4-port hub internally to provide both Isolated I/O and Serial Communication features in one product. The following paragraphs will first describe the Onboard Serial ports, followed by the Isolated Input and Relay Output features.

Serial Communication

This Serial Adapter was designed for effective multipoint transmission in any one of three modes on each channel. These modes are RS232, RS422 and RS485 (EIA485) protocol.

The card features two independent, asynchronous serial ports.

RS422 Balanced Mode Operation

The board supports RS422 communications and uses differential balanced drivers for long range and noise immunity. The board also has the capability to add load resistors to terminate the communications lines. RS422 communications requires that a transmitter supply a bias voltage to ensure a known "zero" state. Also, receiver inputs at each end of the network should be terminated to eliminate "ringing". The board supports biasing by default and supports termination by jumpers on the card. If your application requires the transmitter to be un-biased, please contact the factory.

RS485 Balanced Mode Operation

The board supports RS485 communications and uses differential balanced drivers for long range and noise immunity. RS485 operation involves switchable transceivers and the ability to support multiple devices on a single "party line". The RS485 specification defines a maximum of 32 devices on a single line. The number of devices served on a single line can be expanded by use of "repeaters".

This board also has the capability to add load resistors to terminate the communications lines. RS485 communications requires that one transmitter supply a bias voltage to ensure a known "zero" state when all transmitters are off. Also, receiver inputs at each end of the network should be terminated to eliminate "ringing". The card supports biasing by default and supports termination by jumpers on the card. If your application requires the transmitter to be un-biased, please contact the factory.

COM Port Compatibility

The FT232BM UARTs are used as Asynchronous Communication Elements (ACE). These include 128-byte transmit & 384-byte receive buffers to protect against lost data in multitasking operating systems, while maintaining 100 percent compatibility with the original IBM serial port. The system assigns the address(es).

A crystal oscillator is located on the board. This oscillator permits precise selection of baud rate up to 921.6K bps.

The driver/receiver used (SP491 in non-RS232 modes) is capable of driving extremely long communication lines at high baud rates. It can drive up to +60 mA on balanced lines and receive inputs as low as 200 mV differential signal superimposed on common mode noise of +12 V or -7 V. In case of communication conflict, the driver/receivers feature thermal shutdown.

The driver/receiver used in RS232 mode is the ICL3243.

Isolated Functionality

This board is an ideal solution for adding portable, easy-to-install digital I/O to any computer with a USB port. This is a USB 1.1 device, compatible with both USB 1.1 and USB 2.0 ports. The board is plug-and-play allowing for quick connect/disconnect whenever you need additional I/O on your computer.

Inputs

The board provides four optically-isolated inputs. These inputs can accept either AC or DC signals and are not polarity sensitive. Input signals are rectified by photocoupler diodes while unused power gets dissipated through a 1.8k-ohm resistor in series. The inputs may be driven by either DC sources of 3 to 31 volts (rms) or AC sources at frequencies of 40 Hz to 10 KHz. Standard 12/24 AC control transformer outputs can be accepted as well. External resistors connected in series may be used to extend the input voltage range, however this will raise the input threshold range. Consult with factory for available modified input ranges.

Each input circuit contains a switchable filter that has a 4.7 millisecond time constant. (Without filtering, the response is less than 40 microseconds) The filter must be selected for AC inputs in order to eliminate the on/off response to AC. The filter is also valuable for use with slow DC input signals in a noisy environment. The filter may be switched out for DC inputs in order to obtain faster response. Filters are individually selected by jumpers. The filters are switched into the circuit when the jumpers are installed in position IPFLT0 to IPFLT3.

Outputs

The board's outputs are comprised of four FORM C SPDT electro mechanical relays. These relays are all de-energized at power-on.

USB Connector

The USB connector is a Type B connector and mates with the cable provided. The USB port provides communication signals along with +5 VDC power. The board is powered from the USB port or alternate USB connector.

A second USB Input Connector (P4) in parallel to the Type B (P1) connector is supplied. This second connector is a USB (OTG) connector.

LED

There are four LEDs present on the product, functioning as follows:

Indicator	Function
1	USB Power Present
2	USB Digital I/O Enabled / Ready
3	Serial Port 1 Activity
4	Serial Port 2 Activity

Isolated Input Relay Output Specifications

Isolated Inputs

- Number of inputs: 4
- Type: Non-polarized, optically isolated from each other and from the computer (CMOS compatible)
- Voltage Range: 3 to 31 DC or AC Rms (40 to 10000 Hz)
- Isolation: 500V*(see note) channel-to-ground or channel-to channel
- Input Resistance: 1.8K ohms in series with opto coupler
- Filter Response Times: Rise Time = 4.7 mS / Fall Time = 4.7 mS
- Non-Filter Response Times: Rise Time = 10 uS / Fall Time = 30 uS

*Notes on Isolation: Opto-Isolators and connectors are rated for at least 500V, but isolation voltage breakdowns will vary and is affected by factors like cabling, spacing of pins, spacing between traces on the PCB, humidity, dust and other environmental factors. This is a safety issue so a careful approach is required. For CE certification, isolation was specified at 40V AC and 60V DC. The design intention was to eliminate the influence of common mode. Use proper wiring techniques to minimize voltage between channels and to ground. For example, when working with AC voltages do not connect the hot side of the line to an input. Tolerance of higher isolation voltage can be obtained on request by applying a conformal coating to the board.

Relay Outputs

- Number of outputs: 4 SPDT form C
- Contact Type: Single crossbar; Ag with Au clad
- Rated Load AC: 0.5 A at 125 VAC (62.5 VA max.)
- Rated Load DC: 1A at 24 VDC (30 W max.)
- Max. Switching Voltage: 125 VAC, 60 VDC
- Max. Switching Current: 1A
- Contact Resistance: 100 mΩ max.
- Contact Life: mech'l: 5 million operations min.
- Operating Time: 5 milliseconds max.
- Release Time: 5 milliseconds max.

Auxiliary USB Connector

This board has an additional feature. You can cable an extra USB mini connector to the onboard USB1.1 hub (P5). This would provide an additional, "daisy-chained" USB 1.1 bus to which you can attach any 3rd party USB devices you may wish.

P5

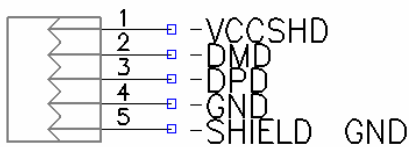

MOLEXPB5

Up to 180mA is still available without requiring the added device to have its own 5VDC power source. The second five pin connector allows the board to have an onboard USB connection rather than the

standard type B connector that is accessible externally on the enclosure. This is useful in OEM embedded or high vibration applications where a tighter fit USB connection is required than a standard USB plug.

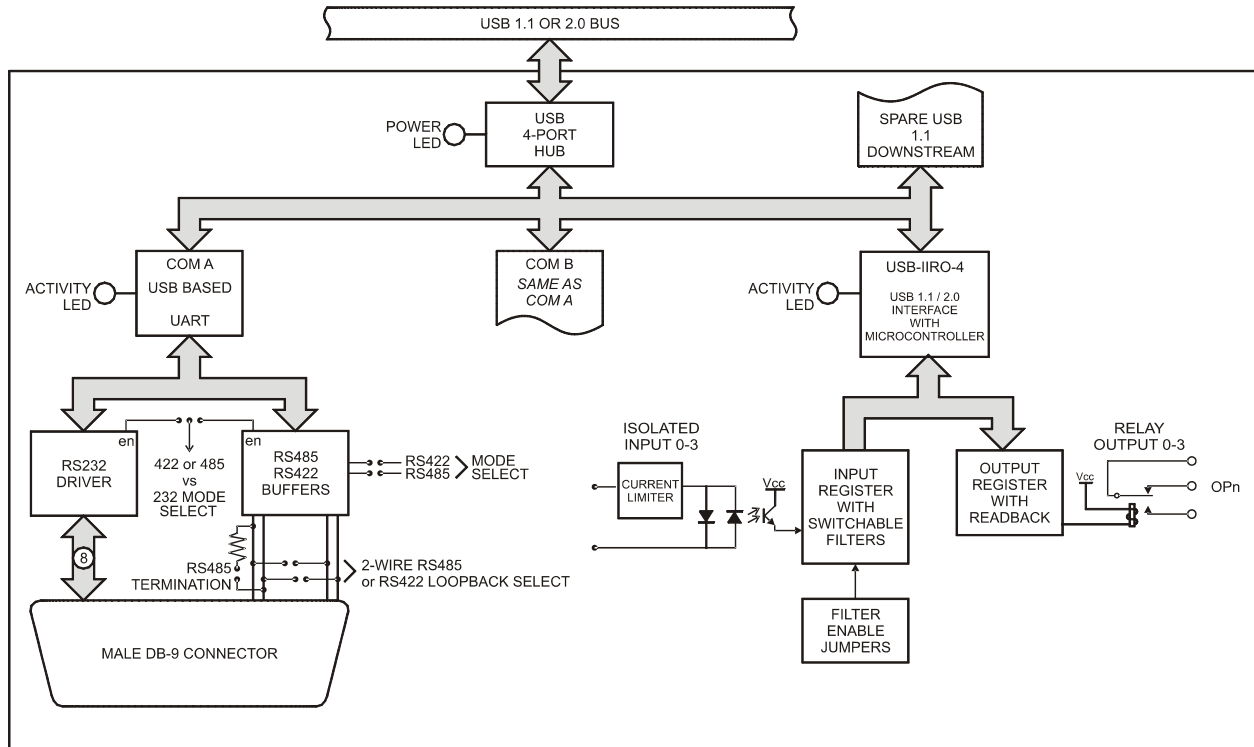

Figure 1-1: Block Diagram

Chapter 2: Installation

Software CD Installation

These paragraphs are intended to detail the software installation steps as well as describe what is being installed.

The software provided with this board is contained on one CD and must be installed onto your hard disk prior to use. To do this, perform the following steps as appropriate for your software format and operating system. Substitute the appropriate drive letter for your CD-ROM or disk drive where you see [D:] in the examples below.

WIN95/98/Me/NT/2000/XP/2003

- a. Place the CD into your CD-ROM drive.
- b. The CD should automatically run the install program. If the install program does not click START | RUN and type `D:\INSTALL`, click OK or press `Enter`.
- c. Follow the on-screen prompts to install the software for this board.

LINUX

1. Please refer to linux.htm on the CD-ROM for information on installing under linux.

Hardware Installation

The board can be installed in any USB 2.0 or USB 1.1 port.

Please install the software package **before** plugging the hardware into the system.

Chapter 3: Option Selection

Refer to the setup programs on the CD provided with the board. Also, refer to the Block diagram and the Option Selection Map when reading this section of the manual.

Terminations

A transmission line should be terminated at the receiving end in its characteristic impedance. Installing a jumper at the locations labeled RS485-LD applies a 120Ω load across the transmit/receive input/output for RS485 operation.

Jumpers having to do with the termination of each channel are located near the output connector. They are labeled by channel. The load jumper is labeled "TERM". The other two jumpers are used to connect the transmit and receive lines for the two wire RS485 mode.

In RS485 operations where there are multiple terminals, only the RS485 ports at each end of the network should have terminating impedance as described above. To terminate the COM A port, place a jumper at the location labeled Ch A - RS485. To terminate the COM B port place jumpers at the location labeled Ch B - RS485.

Also, for RS485 operation, there must be a bias on the TRX+ and TRX- lines. If the adapter is not to provide that bias, consult the factory for technical support.

Data Cable Wiring

Signal	Pin Connection
Ain/out+	2
Ain/out-	3
100Ω to Ground	5

Filter Response Switch

Jumpers are used to select input filtering on a channel-by-channel basis. When jumper FLT0 is installed, additional filtering is introduced for bit 0, FLT 1 for bit 1, etc.

Jumper Selection	Bit Filtered
FLT-0	IN00
FLT-1	IN01
FLT-2	IN02
FLT-3	IN03

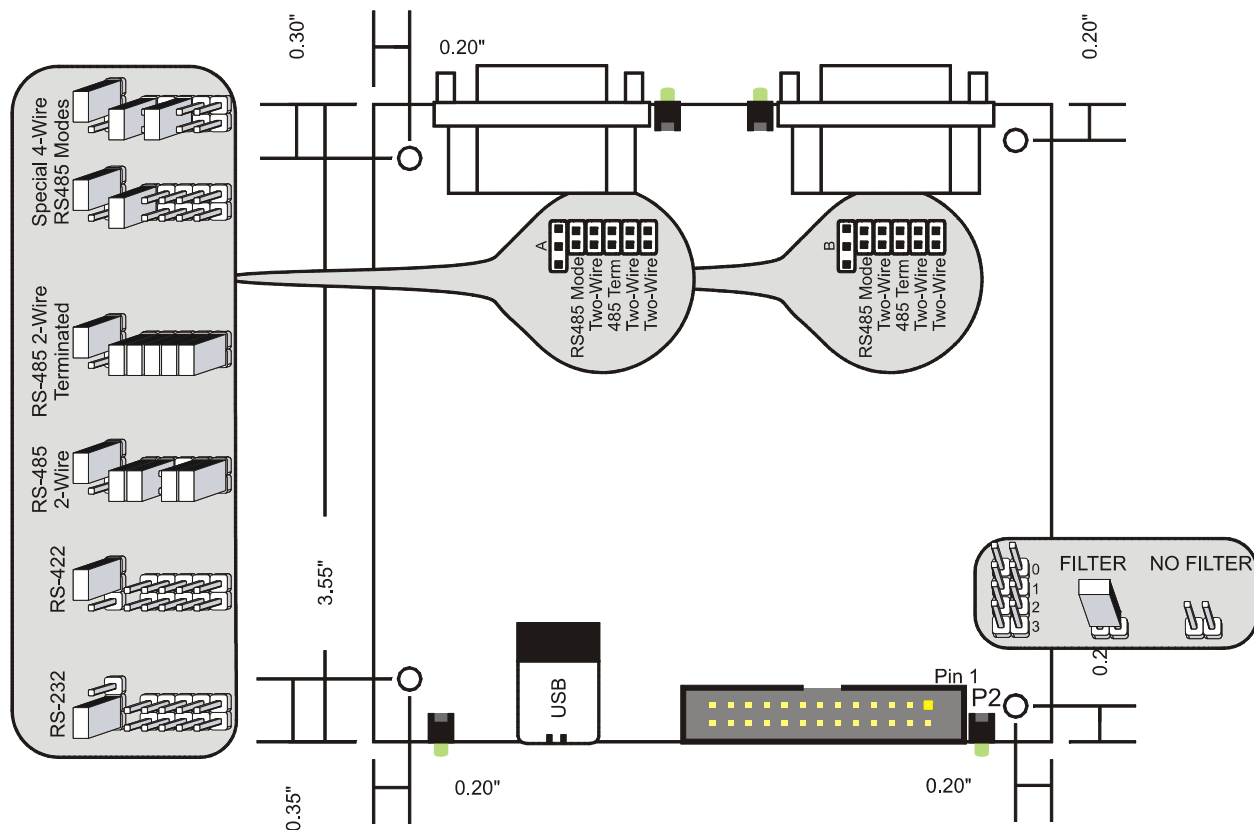

Figure 3-1: Option Selection Map

This board has 2 separate channels which can be individually configured. Each channel can be used in one of four modes:

- 1 RS232 - Install the top jumper in the RS232 position (left)
- 2 RS422 - Install the top jumper in the RS422/RS485 position (right)
- 3 RS485 (4 wire) - Install the top jumper in the RS422/RS485 position (right) and the RS485 Mode jumper
- 4 RS485 (2 wire) - Install the top jumper in the RS422/RS485 position (right), the RS485 Mode jumper, the RS485 TxRx+ jumper and the RS485 TxRx- jumper.

To provide a termination load in the RS485 mode, install the appropriate RS485 TERM jumper.

The jumpers on the card must be properly placed in order to have the card function properly.

Note: Any unneeded jumpers that are installed can cause the adapter to function incorrectly.

Chapter 4: Address Selection

Use the provided driver to access the USB board. This driver will allow you to determine how many supported USB devices are currently installed, and each device's type. This information is returned as a Vendor ID (VID), Product ID (PID) and Device Index.

The board's VID is "0x1605", and its PID is "0x8030".

The Device Index is determined by how many of the device you have in your system, and provides a unique identifier allowing you to access a specific board at will.

Chapter 5: Programming

The driver software provided with the board uses a 32-bit .dll front end compatible with any Windows programming language. Samples provided in Borland C++Builder, Borland Delphi, Microsoft Visual Basic, and Microsoft Visual C++ demonstrate the use of the driver.

The following functions are provided by the driver in Windows.

These functions will allow you to read or write individual bits, bytes, or the entire board worth of data.

For detailed information on each function refer to the .html Driver Manual located in the Win32 directory for this board.

```
unsigned long GetDevices(void )
unsigned long QueryDeviceInfo(DeviceIndex, pPID, pName, pDIOBytes, pCounters)
unsigned long DIO_Configure(DeviceIndex, bTristate, pOutMask, pData)
unsigned long DIO_Write1(DeviceIndex, BitIndex, bData)
unsigned long DIO_Write8(DeviceIndex, ByteIndex, Data)
unsigned long DIO_WriteAll(DeviceIndex,pData)
unsigned long DIO_Read8(DeviceIndex, ByteIndex,pBuffer)
unsigned long DIO_ReadAll(DeviceIndex,Buffer)
```

Please note, this board does not contain any 8254 devices, and the following functions will not be useful:

```
unsigned long CTR_8254Mode(DeviceIndex, BlockIndex, CounterIndex, Mode)
unsigned long CTR_8254ModeLoad(DeviceIndex, BlockIndex, CounterIndex,Mode, LoadValue)
unsigned long CTR_8254ReadModeLoad(DeviceIndex, BlockIndex, CounterIndex, Mode, LoadValue,
pReadValue)
unsigned long CTR_8254Read(DeviceIndex, BlockIndex, CounterIndex, pReadValue)
unsigned long CTR_StartOutputFreq(DeviceIndex, CounterIndex, pHz)
```

Chapter 6: Connector Pin Assignments

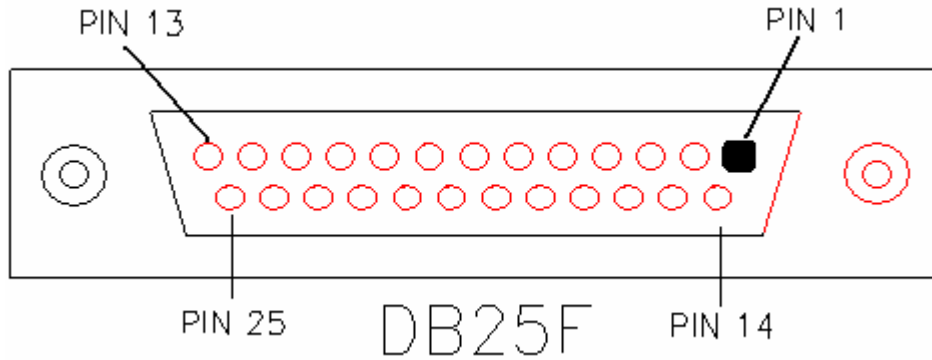

DB25F Connector	Function	IDC
1	Input 0 A	1
2	Input 1 A	3
3	Input 2 A	5
4	Input 3 A	7
5	Ground	9
6	+5V	11
7	NC	13
8	Relay 0 Common	15
9	Relay 1 Normally Open	17
10	Relay 1 Normally Closed	19
11	Relay 2 Common	21
12	Relay 3 Normally Open	23
13	Relay 3 Normally Closed	25
14	Input 0 B	2
15	Input 1 B	4
16	Input 2 B	6
17	Input 3 B	8
18	Ground	10
19	+5V	12
20	Relay 0 Normally Open	14
21	Relay 0 Normally Closed	16
22	Relay 1 Common	18
23	Relay 2 Normally Open	20
24	Relay 2 Normally Closed	22
25	Relay 3 Common	24
NC	NC	26

Table 6-1: Enclosure Mounted DB25 Pin-out and 26 Pin Header Translation

DB-9 Male Pin for each of Ch A-B	RS-232 Signals (Industry Standard)	RS-485 Signals (2 Wire)	RS-422 Signals (Also 4wire RS485)
Ch x – 1	DCD	RX-/TX-	RX-
Ch x – 2	RX	TX+/RX+	TX+
Ch x – 3	TX	TX-/RX-	TX-
Ch x – 4	DTR		
Ch x – 5	Gnd	Gnd	Gnd
Ch x – 6	DSR		
Ch x – 7	RTS		
Ch x – 8	CTS		
Ch x – 9	RI	RX+/TX+	RX+

Table 6-2: Serial Connector Pin Assignments

Customer Comments

If you experience any problems with this manual or just want to give us some feedback, please email us at: ***manuals@acesio.com***. Please detail any errors you find and include your mailing address so that we can send you any manual updates.

10623 Roselle Street, San Diego CA 92121
Tel. (858)550-9559 FAX (858)550-7322
www.acesio.com



Manual USB-IIRO4-2SM