



## XPort™ Integration Guide

## Copyright and Trademark

© 2004, Lantronix. All rights reserved. No part of the contents of this book may be transmitted or reproduced in any form or by any means without the written permission of Lantronix. Printed in the United States of America.

XPort, with its patent-pending technology, is a trademark of Lantronix.

Ethernet is a trademark of XEROX Corporation. UNIX is a registered trademark of The Open Group. Windows 95, Windows 98, Windows 2000, Windows NT, and Windows XP are trademarks of Microsoft Corp. Netscape is a trademark of Netscape Communications Corporation.

## Contacts

### Lantronix Corporate Headquarters

15353 Barranca Parkway  
Irvine, CA 92618, USA  
Phone: 949-453-3990  
Fax: 949-453-3995

### Technical Support

Fax: 949-450-7226  
Online: [www.lantronix.com/support](http://www.lantronix.com/support)  
Email: [support@lantronix.com](mailto:support@lantronix.com)

### Sales Offices

For a current list of our domestic and international sales offices, go to the Lantronix web site at <http://www.lantronix.com/about/contact/index.html>

## Disclaimer and Revisions

Operation of this equipment in a residential area is likely to cause interference, in which case the user, at his or her own expense, will be required to take whatever measures may be required to correct the interference.

**Note:** *This product has been designed to comply with the limits for a Class B digital device pursuant to Part 15 of FCC Rules. These limits are designed to provide reasonable protection against harmful interference in a residential installation. This equipment generates, uses, and can radiate radio frequency energy, and if not installed and used in accordance with this guide, may cause harmful interference to radio communications.*

Changes or modifications to this device not explicitly approved by Lantronix will void the user's authority to operate this device.

**Note:** *With the purchase of XPort, the OEM agrees to an OEM firmware license agreement that grants the OEM a non-exclusive, royalty-free firmware license to use and distribute the binary firmware image provided, only to the extent necessary to use the XPort hardware. For further details, please see the XPort OEM firmware license agreement.*

Date	Rev.	Comments
11/03	A	Initial Release
4/04	B	Firmware 1.6 features; information to support XPort-03
6/04	C	Technical specifications updated
8/04	D	Firmware 1.8 features; added XPort-485 information

# Contents

Copyright and Trademark _____	2
Contacts _____	2
Disclaimer and Revisions _____	2
<b>1: Introduction</b> _____	<b>5</b>
About the Integration Guide _____	5
Additional Documentation _____	5
<b>2: Description and Specifications</b> _____	<b>6</b>
The XPort _____	6
XPort Block Diagram _____	6
PCB Interface _____	7
Ethernet Interface _____	9
LEDs _____	9
Dimensions _____	10
Recommended PCB Layout _____	11
Product Information Label _____	11
Technical Specifications _____	12
<b>3: Development Kit</b> _____	<b>14</b>
Contents of the Kit _____	14
Evaluation Board Description _____	14
Evaluation Board Block Diagram _____	15
Major Components _____	15
Serial RS-232 Interface _____	15
RS-232 Port _____	16
Power Supply _____	16
General Control PLD _____	16
Configuration Switch Bank _____	16
SW1-2 Options _____	17
SW1-3 Options _____	18
SW1-4, SW1-5 Options _____	19
Timer _____	20
Board Layout _____	21
Component Identification _____	21
<b>A: XPort-485 Connection Diagram</b> _____	<b>22</b>
<b>B: Compliance and Warranty Information</b> _____	<b>23</b>
Compliance Information _____	23
Warranty _____	24

---

## List of Figures

Figure 2-1. Side View of the -03 XPort .....	6
Figure 2-2. XPort Block Diagram .....	7
Figure 2-3. XPort LEDs .....	9
Figure 2-4. Front View .....	10
Figure 2-5. Bottom View .....	10
Figure 2-6. Side View.....	10
Figure 2-7. PCB Layout .....	11
Figure 2-8. Product Label .....	12
Figure 3-1. SW1-2 OFF .....	17
Figure 3-2. SW1-2 ON .....	18
Figure 3-3. SW1-3 OFF .....	18
Figure 3-4. SW1-3 ON .....	18
Figure 3-5. SW1-5 OFF and SW1-4 ON .....	19
Figure 3-6. SW1-5 ON and SW1-4 ON.....	19
Figure 3-7. JP4 Configurable Pins Interface Header Footprint .....	20
Figure 3-8. Board Layout .....	21

## List of Tables

Table 2-1. PCB Interface Signals.....	7
Table 2-2. Ethernet Interface Signals (Industry Standards).....	9
Table 2-3. XPort LED Functions (XPort-03 and greater only).....	9
Table 2-4. Technical Specifications .....	12
Table 3-1. RS-232 Signals.....	15
Table 3-2. Configuration Switch Settings.....	17
Table 3-3. CP1 Status Indicator.....	18
Table 3-4. LED States.....	19
Table 3-5. JP4 Connections.....	20
Table 3-6. Board Components.....	21

# 1: Introduction

## About the Integration Guide

This guide provides the information needed to test the XPort™ device server on the XPort Evaluation Board. This manual is intended for engineers responsible for integrating the XPort into their product.

**Note:** This document covers XPort™ Device Server versions XP1001000-01 (XPort-01), XP1001000-03 (XPort-03), and XP1004000-03 (XPort-485).

## Additional Documentation

The following guides are available on the product CD and the Lantronix Web site ([www.lantronix.com](http://www.lantronix.com))

<b>XPort™ Getting Started</b>	Provides the steps for getting the hardware and software up and running.
<b>XPort™ User Guide</b>	Provides information needed to configure, use, and update the XPort firmware.
<b>DeviceInstaller User Guide</b>	Provides instructions for using the Windows-based utility to configure the XPort and other Lantronix device servers.
<b>Com Port Redirector User Guide</b>	Provides information on using the Windows-based utility to create a virtual com port.
<b>Web Enabling Your Device Server</b>	Explains in detailed steps how to create custom web pages for Lantronix device servers.

In addition to this documentation, the supplied CD contains a configurable pins control web applet that lets you view the state of the configurable GPIO pins. This applet is provided in the `Sample Code and Solutions` folder.

For firmware versions 1.3 and earlier, the corresponding applet file is `xptcpctl102.cob`. For later firmware versions (greater than version 1.3), the corresponding applet file is `xpt_gpioctl1_154.cob`.

## 2: Description and Specifications

The XPort embedded device server is a complete network-enabling solution enclosed within an RJ45 package. This miniature serial-to-Ethernet converter empowers original equipment manufacturers (OEMs) to quickly and easily go to market with networking and web page serving capabilities built into their products.

### The XPort

The XPort contains Lantronix's own DSTni controller, with 256 Kbytes of SRAM, 2 Kbytes of boot ROM for the XPort-01 or 16 Kbytes of boot ROM for the XPort-03 or greater, and integrated AMD 10/100 PHY.

The XPort also contains the following:

- ◆ 3.3-volt serial interface
- ◆ All I/O pins are 5V tolerant (XPort-03 or greater only)
- ◆ 4-Mbit flash memory
- ◆ Ethernet magnetics
- ◆ Power supply filters
- ◆ Reset circuit
- ◆ +1.8V regulator
- ◆ 25-MHz crystal and Ethernet LEDs

The XPort requires +3.3-volt power and is designed to operate in an extended temperature range (see technical data).

Figure 2-1. Side View of the -03 XPort

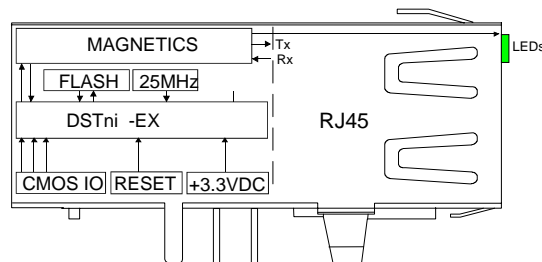

### XPort Block Diagram

The following drawing is a block diagram of the XPort showing the relationships of the components.

Figure 2-2. XPort Block Diagram

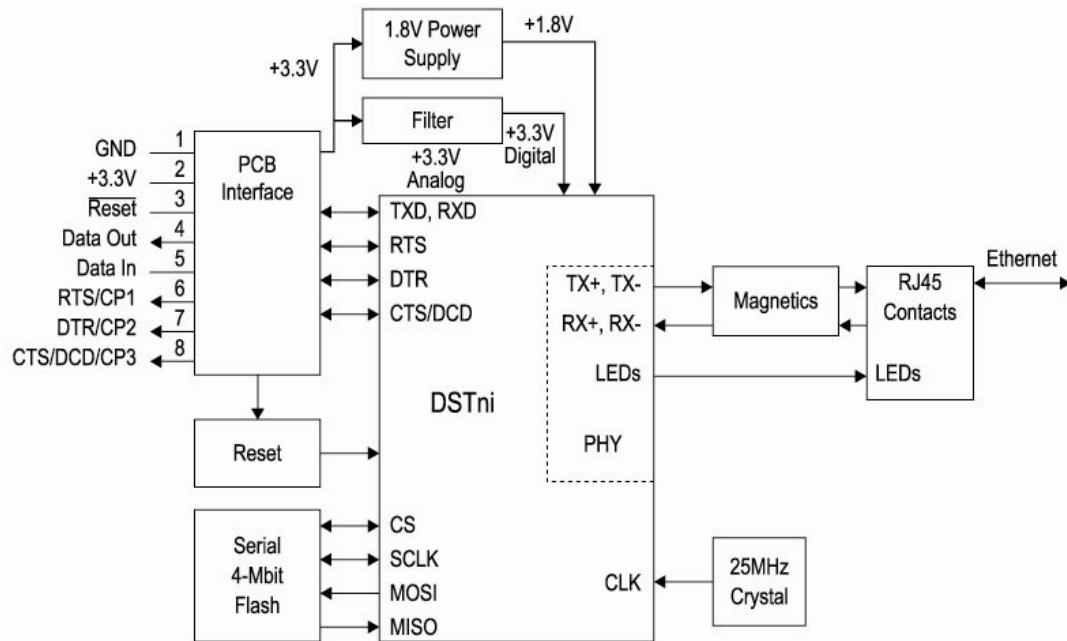

## PCB Interface

The XPort has a serial port compatible with data rates up to 920 kbps (in high-performance mode) for the XPort-03 and greater, and at 230 kbps for the XPort-01. The serial signals (pins 4–8) are 3.3V CMOS logic level (5V tolerant for the XPort-03 and greater only). The serial interface pins include +3.3V, ground, and reset. The serial signals usually connect to an internal device, such as a UART. For applications requiring an external cable running with RS-232 or RS422/485 voltage levels, the XPort must interface to a serial transceiver chip. We supply an RS-232 transceiver on the XPort Evaluation Board for this purpose. There is an XPort option available for interfacing with RS422/485.

Table 2-1. PCB Interface Signals

Signal Name	XPort Pin #	Primary Function
GND	1	Circuit ground
3.3V	2	+3.3V power in
Reset	3	External reset in
Data Out	4	Serial data out (driven by DSTni's built-in UART)
Data In	5	Serial data in (read by DSTni's built-in UART)
CP1/RTS (Configurable Pin 1)	6	CP1 can be configured as follows: <ul style="list-style-type: none"> <li>• <b>Flow control:</b> RTS (Request to Send) <b>output</b> driven by DSTni's built-in UART for connection to CTS of attached device.</li> <li>• <b>Programmable input/output:</b> CP1 can be driven or read through software control, independent of serial port activity.</li> </ul>

## Description and Specifications

---

Signal Name	XPort Pin #	Primary Function
CP2/DTR (Configurable Pin 2)	7	CP2 can be configured as follows: <ul style="list-style-type: none"><li>• <b>Modem control:</b> DTR (Data Terminal Ready) <b>output</b> driven by DSTni's built-in UART for connection to DCD of attached device.</li><li>• <b>Programmable input/output:</b> CP2 can be driven or read through software control, independent of serial port activity.</li></ul>
CP3/CTS/DCD (Configurable Pin 3)	8	CP3 can be configured as follows: <ul style="list-style-type: none"><li>• <b>Flow control:</b> CTS (Clear to Send) <b>input</b> read by DSTni's built-in UART for connection to RTS of attached device.</li><li>• <b>Modem control:</b> DCD (Data Carrier Detect) <b>input</b> read by DSTni's built-in UART for connection to DTR of attached device.</li><li>• <b>Programmable input/output:</b> CP3 can be driven or read through software control, independent of serial port activity.</li></ul>



## Ethernet Interface

The Ethernet interface magnetics, RJ45 connector, and Ethernet status LEDs are all in the device server shell.

**Table 2-2. Ethernet Interface Signals (Industry Standards)**

Signal Name	DIR	Contact	Primary Function
TX+	Out	1	Differential Ethernet transmit data +
TX-	Out	2	Differential Ethernet transmit data -
RX+	In	3	Differential Ethernet receive data +
RX-	In	6	Differential Ethernet receive data -
Not used		4	Terminated
Not used		5	Terminated
Not used		7	Terminated
Not Used		8	Terminated
SHIELD			Chassis ground

## LEDs

The XPort contains the following LEDs:

- ◆ Link (bi-color, left LED) — XPort-03 and greater only
- ◆ Activity (bi-color, right LED)

**Figure 2-3. XPort LEDs**

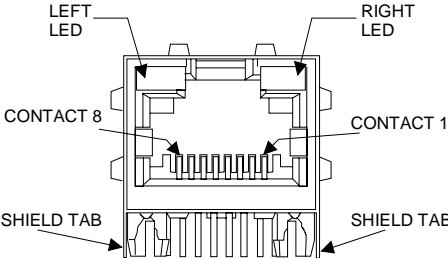

**Table 2-3. XPort LED Functions (XPort-03 and greater only)**

Link LED Left Side		Activity LED Right Side	
Color	Meaning	Color	Meaning
Off	No Link	Off	No Activity
Amber	10 Mbps	Amber	Half Duplex
Green	100 Mbps	Green	Full Duplex

## Dimensions

The XPort dimensions are shown in the following drawings.

**Figure 2-4. Front View**

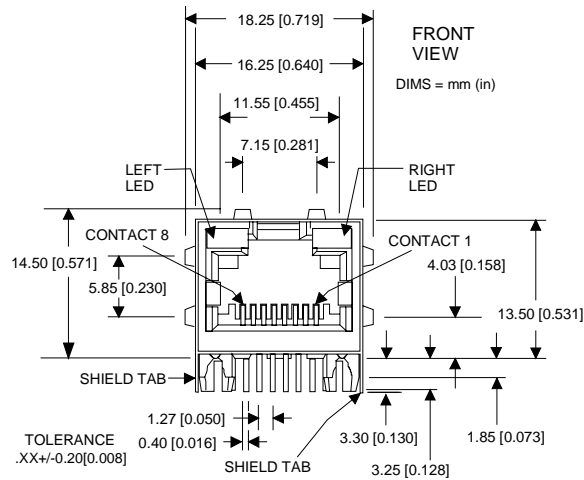

**Figure 2-5. Bottom View**

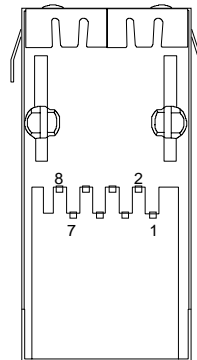

**Figure 2-6. Side View**

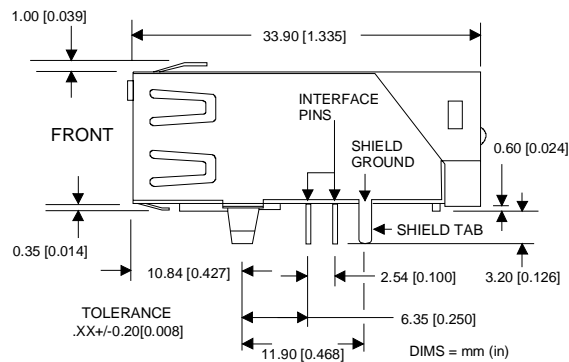

### Recommended PCB Layout

The hole pattern and mounting dimensions for the XPort device server are shown in the following drawing. For proper heat dissipation, it is recommended that the PCB have approximately 1 square inch of copper attached to the shield tabs. The shield tabs are an important source of heat sinking for the device.

Figure 2-7. PCB Layout

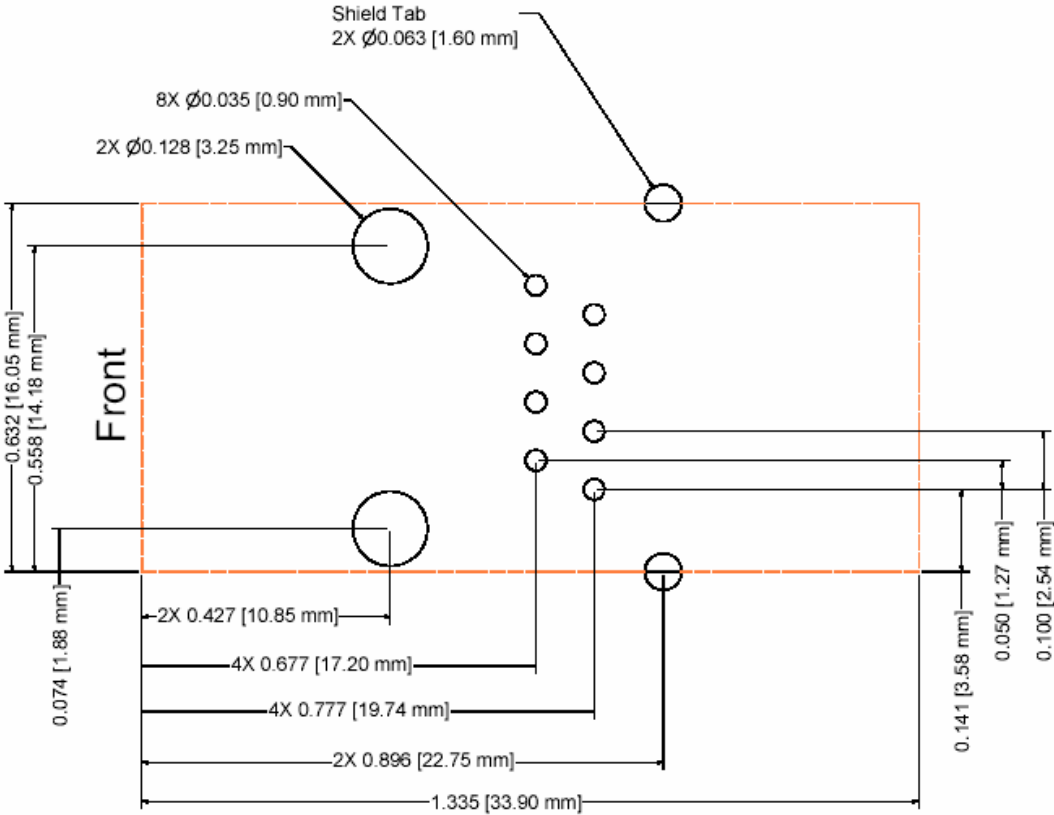

### Product Information Label

The product information label contains important information about your specific unit, such as its product ID (name), bar code, part number, and Ethernet (MAC) address.

Figure 2-8. Product Label



## Technical Specifications

Table 2-4. Technical Specifications

Category	Description
CPU, Memory	Lantronix DSTni-EX 186 CPU, 256-Kbyte zero wait state SRAM, 512-Kbyte flash, 2-Kbyte boot ROM (XPort-01), 16-Kbyte boot ROM (XPort-03 and greater)
Firmware	Upgradeable via TFTP and serial port
Reset Circuit	Internal 200ms power-up reset pulse. Power-drop reset triggered at 2.6V. External reset input causes an internal 200ms reset.
Serial Interface	CMOS (Asynchronous) 3.3V-level signals Rate is software selectable: XPort-01: 300 bps to 230400 bps XPort-03 and greater: 300 bps to 921600 bps
Serial Line Formats	Data bits: 7 or 8 Stop bits: 1 or 2 Parity: odd, even, none
Modem Control	DTR/DCD, CTS, RTS
Flow Control	XON/XOFF (software), CTS/RTS (hardware), None
Programmable I/O	3 PIO pins (software selectable), sink or source 4mA max.
Network Interface	RJ45 Ethernet 10Base-T or 100Base-TX (auto-sensing)
Compatibility	Ethernet: Version 2.0/IEEE 802.3 (electrical), Ethernet II frame type
Protocols Supported	ARP, UDP/IP, TCP/IP, Telnet, ICMP, SNMP, DHCP, BOOTP, TFTP, Auto IP, SMTP, and HTTP
LEDs	10Base-T and 100Base-TX Link Activity, Full/half duplex. Software generated status & diagnostic signals can optionally drive external LEDs through CP1 & CP3.
Management	Internal web server, SNMP (read only) Serial login, Telnet login
Security	Password protection, locking features, optional Rijndael 256-bit encryption
Internal Web Server	Serves static web pages and Java applets Storage capacity: 384 Kbytes
Weight	0.34 oz (9.6 grams)
Material	Metal shell, thermoplastic case
Temperature	Operating range: XPort-01: -40°C to +85°C (-40°F to 185°F) XPort-03 and greater: -40°C to +85°C (-40°F to 185°F) normal mode, -40°C to +75°C (-40°F to 167°F) high-performance mode
Shock/Vibration	Non-operational shock: 500 g's Non-operational vibration: 20 g's

<b>Category</b>	<b>Description</b>
Warranty	One year limited warranty (-01 models) Two year limited warranty (-03 models)
Included Software	Windows™ 98/NT/2000/XP-based Device Installer configuration software and Windows™-based Com Port Redirector
EMI Compliance	Radiated and conducted emissions - complies with Class B limits of EN 55022:1998 Direct & Indirect ESD - complies with EN55024:1998 RF Electromagnetic Field Immunity - complies with EN55024:1998 Electrical Fast Transient/Burst Immunity - complies with EN55024:1998 Power Frequency Magnetic Field Immunity - complies with EN55024:1998 RF Common Mode Conducted Susceptibility - complies with EN55024:1998

## 3: Development Kit

The XPort Development Kit includes everything you need to begin to integrate the XPort into your product design.

### Contents of the Kit

The development kit contains the following items:

- ◆ XPort Evaluation Board
- ◆ XPort Device Server
- ◆ +5VDC Universal Power Supply with snap-fit plugs for different countries
- ◆ RS-232 cable, DB9M/F
- ◆ CAT5e UTP RJ45M/M Ethernet cable
- ◆ CD with software utilities and documentation (in PDF format)
- ◆ Serial adaptor, 25-pin to 9-pin



### Evaluation Board Description

The XPort Evaluation Board provides a test platform for the Lantronix XPort device server.

The XPort Evaluation Board supplies an RS-232 serial interface to 3.3V CMOS level interface connection for the XPort. It also supplies the XPort device server with +3.3V. Evaluation board controls include a programmable logic device (PLD), reset push button switch, DIP switch, timer circuit, and reset circuit.

In addition to the status LEDs on the XPort, the evaluation board contains multiple LEDs. The power supply drives the red LED. The PLD drives the remaining LEDs; in the basic mode of operation, these LEDs indicate whether the RS-232 interface is

valid, whether the serial interface transmit data and serial interface receive data are active, and the state of the three configurable pins, CP1, CP2, and CP3.

The PLD and a six-position DIP switch control the evaluation board mode of operation. The switch outputs are inputs to the PLD to select the desired mode of operation.

### Evaluation Board Block Diagram

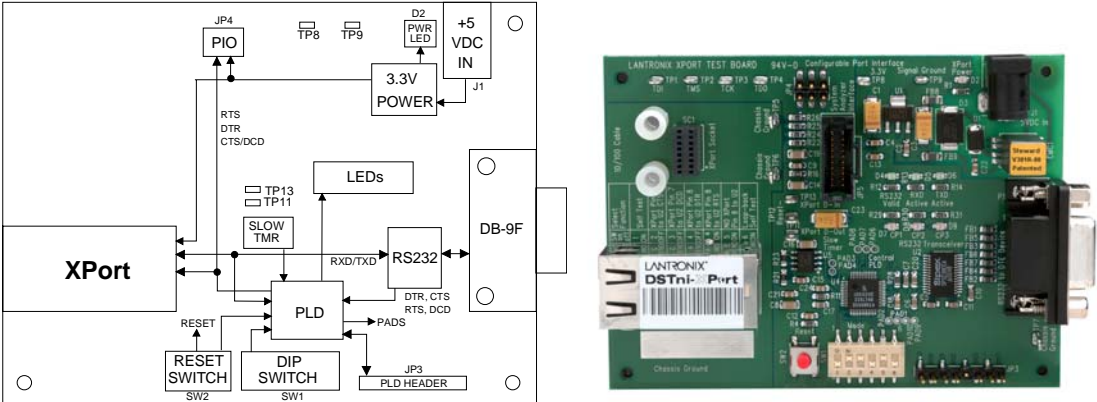

### Major Components

The major components of the evaluation board include:

- ◆ RS-232 transceiver
- ◆ Universal Power Adapter
- ◆ Reset switch
- ◆ DIP switch
- ◆ DB9 interface connector (DCE)
- ◆ Test points to monitor all XPort pins
- ◆ 6-pin header (JP4) for connecting user devices or circuits to CP1, CP2, and CP3.
- ◆ Power, signal ground, and reset inputs are also available on JP4.

### Serial RS-232 Interface

The RS-232 level serial interface is implemented with a transceiver that converts 3.3V CMOS levels to RS-232 levels. A straight-through serial cable with 9-pin connectors (M/F) is all you need to connect to a DTE device such as a PC.

The table below lists the RS-232 signals. Note that XPort signal pins 6, 7, and 8 are configurable pins you can optionally set for functions other than RS-232 control. The configuration DIP switch determines whether or not to route the XPort configurable pins to the RS-232 converter.

Table 3-1. RS-232 Signals

XPort Signal	XPort Pin #	Direction	DB9 Pin #	DTE Device Signal
DTR	7	Out	1	DCD
Data Out	4	Out	2	RXD
Data In	5	In	3	TXD
DCD	8	In	4	DTR

XPort Signal	XPort Pin #	Direction	DB9 Pin #	DTE Device Signal
Ground	1	--	5	GND
CTS	8	In	7	RTS
RTS	6	Out	8	CTS

**Note:** The supplied CD contains a configurable pins control web applet that lets you view the state of the configurable GPIO pins. This applet is provided in the *Sample Code and Solutions* folder.

### RS-232 Port

The evaluation board uses a TI SN75C3238 IC to convert all RS-232 interface signals to 3.3V CMOS-level XPort signals.

We selected the interface IC for its capability of true RS-232-level performance from a +3.3V power source and for its 15 kV ESD protection. The part also includes an RS-232 valid output that lights an LED by means of the PLD circuit.

### Power Supply

The evaluation board contains a +3.3V regulator that receives input power by means of a 2.5mm input power jack. The input power should be 5VDC from a regulated DC source. The evaluation kit provides a +5VDC power module.

We recommend that you also connect the evaluation board to an earth ground. You can use the chassis ground rectangle (copper tape), TP7, or the shell of the DB9 connector.

### General Control PLD

The purpose of the PLD is to provide general evaluation board mode control and LED signal-level monitoring. The PLD works with the 6-position mode control switch (SW1) and the timer and reset circuits to provide mode control.

The PLD is a Lattice ISPLSI2032VE part, which is contained in a 48-pin TQFP package. This part contains 32 I/O and 32 microcells and is in-circuit programmable. A 1x8-pin header (JP3) provides for standard Lattice in-circuit programming.

### Configuration Switch Bank

Switch module SW1 contains six independent switches for configuring the PLD on the evaluation board. The PLD controls how the signals from the XPort are routed on the evaluation board. Positions 1 and 6 are for self-test. Positions 2 through 5 are for configuring XPort pins for various operations.

Three XPort pins are configurable pins. You can configure these pins for hardware flow control or as LED status indicators on the evaluation board. For information about configuring these pins, see the *XPort User Guide*.

On the evaluation board, configurable pins are shown as CP1, CP2, CP3, and SW1 switch positions are shown as SW1-1 through SW1-6.

**Note:** In the following sections, the terms *LED1* and *LED3* refer to diagnostic modes. You can put control of two of the XPort pins into these modes.



Table 3-2. Configuration Switch Settings

SW1	POS	Function
1	ON	SW1-1 and SW1-6 ON for self-test mode. (Factory test)
	OFF	Normal mode.
6	ON	SW1-1 and SW1-6 ON for self-test mode. (Factory test)
	OFF	Normal mode.
2	OFF	XPort CP1/RTS (pin 6) is connected to the RS-232 transceiver, which connects to the CTS of an attached device through DB9 pin 8. Use this setting if CP1 is set up for hardware flow control.
	ON	XPort CP1/RTS (pin 6) is <i>not</i> connected to an RS-232 transceiver. Use this setting if CP1 is set up as an IN1, OUT1, or LED1.
3	OFF	XPort CP2/DTR (pin 7) is connected to the RS-232 transceiver, which connects to DCD of an attached device through DB9 pin 1. Use this setting if CP2 is set up for hardware handshaking.
	ON	XPort CP2/DTR (pin 7) is <i>not</i> connected to the transceiver. Use this setting if CP2 is set up as an IN2 or OUT2.
4	OFF	Use this setting when XPort CP3/CTS/DCD (pin 8) is set up for hardware handshaking. With SW1-5 configured appropriately, CP3 will connect to DTR of an attached device.
	ON	Use this setting when XPort CP3/CTS/DCD (pin 8) is set up for hardware flow control. With SW1-5 configured appropriately, CP3 will connect to RTS of an attached device.
5	OFF	XPort CP3/CTS/DCD (pin 8) is connected to the RS-232 transceiver, which connects to either the DTR (DB9 pin 4) or the RTS (DB9 pin 7) of an attached device, depending on the setting on SW1-4. Use this setting if CP3 is set up for hardware flow control.
	ON	XPort CP3/CTS/DCD (pin 8) is not connected to the transceiver. Use this setting if CP3 is set up as an IN3, OUT3, or LED3.

## SW1-2 Options

SW1-2 controls the routing of the CP1/RTS (configurable pin 1) signal from the XPort. CP1 is connected to pin 6 of the XPort and can be software configured as CTS, IN1, OUT1, or LED1. SW1-2 is an input to the PLD, which does the actual switching. The drawings represent the logical switching function.

In this drawing, SW1-2 is OFF, which connects XPort pin 6 to the RS-232 transceiver. The XPort configurable pin 1 (CP1) is configured for CTS.

Figure 3-1. SW1-2 OFF

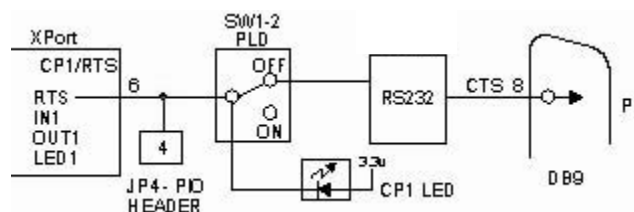

In the next drawing, SW1-2 is ON, which disconnects pin 6 from the RS-232 transceiver. The XPort configurable pin 1 (CP1) is configured for LED1.

Figure 3-2. SW1-2 ON

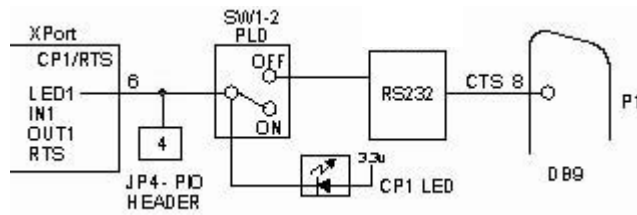

When configurable pin 1 is configured for LED1, it functions as a status indicator for the serial port.

Table 3-3. CP1 Status Indicator

Condition	CP1 LED State
Idle channel	Solid on
Connected to network	4 blinks every 4 seconds

CTS and RTS work together for hardware flow control. Configure CP3 as RTS when CP1 is configured as CTS. Select hardware flow control as described in *Flow* in the *XPort User Guide*. See the *Device Installer User Guide* for information on configuring CP1 as IN1 or OUT1.

### SW1-3 Options

SW1-3 controls the routing of the CP2/DTR (configurable pin 2) signal from the XPort. CP2 is connected to pin 7 of the XPort and can be software-configured as DCD, IN2, or OUT2. SW1-3 is an input to the PLD that does the actual switching. The drawings represent the logical switching function.

In this drawing, SW1-3 is OFF, which connects XPort pin-7 to the RS-232 transceiver. The XPort CP2 is configured for DCD.

Figure 3-3. SW1-3 OFF

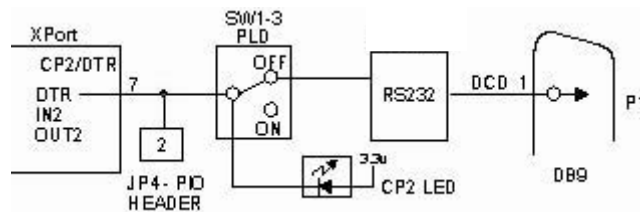

In the drawing below, SW1-3 is ON, which disconnects XPort pin-7 from the RS-232 transceiver. The XPort CP2 is configured for OUT2.

Figure 3-4. SW1-3 ON

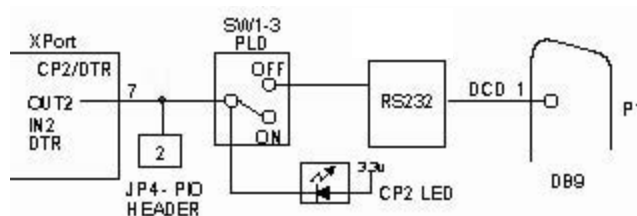

See the *Device Installer User Guide* for information on configuring CP2 as IN2 or OUT2.

## SW1-4, SW1-5 Options

SW1-5 controls the routing of the CP3/CTS/DCD signal from the XPort. CP3 is connected to pin 8 of the XPort, and you can software configure it as RTS, LED3, DTR, IN3, or OUT3. With SW1-5 in the OFF position, the CP3 signal is routed to SW1-4. SW1-4 and SW1-5 are inputs to the PLD, which does the actual switching. The drawings represent the logical switching functions.

CP3 options are a little more complicated because both SW1-4 and SW1-5 are used in the configuration setup. In this drawing, SW1-5 is OFF, which connects XPort pin-8 to the RS-232 transceiver. The XPort CP3 is configured for RTS. SW1-4 is ON, routing the signal from XPort pin-8 to P1 pin-7 (RTS).

Figure 3-5. SW1-5 OFF and SW1-4 ON

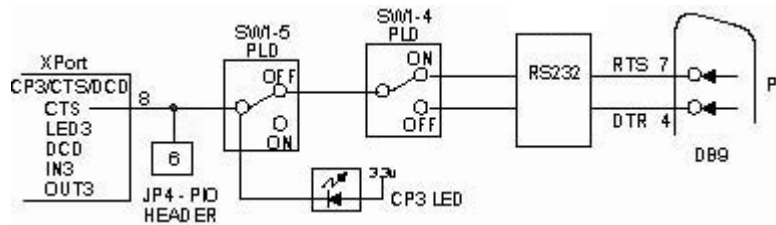

In the next drawing, SW1-5 is ON, which disconnects XPort pin-8 from the RS-232 transceiver. The XPort CP3 is configured for LED3.

Figure 3-6. SW1-5 ON and SW1-4 ON

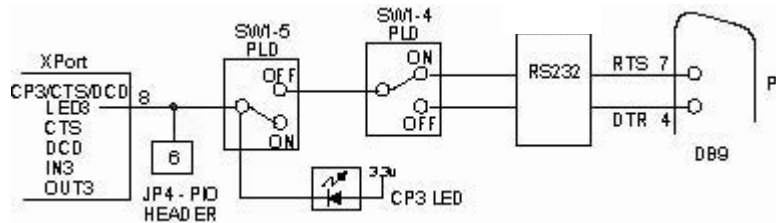

When CP3 is configured for LED3, it functions as a diagnostic indicator. The LED3 signal in combination with the LED1 signal indicates diagnostic information as shown in the following table.

**Note:** CP1 must be configured for LED1, and CP3 must be configured for LED3 for diagnostic mode.

Table 3-4. LED States

Condition	CP3 LED (LED3)	CP1 LED (LED1)
No errors	OFF	ON
Network controller error	ON	Blink 3x/4 sec OFF
Duplicate IP address present	ON	Blink 5x/4 sec OFF
No DHCP response	Blink 2x/sec	Blink 5x/4 sec OFF
Setup menu active	Blink 2x/sec	See Note.

**Note:** During a Telnet connection, CP1 LED (LED1) is ON. For a serial port connection, CP1 LED (LED 1) blinks for 2 seconds, then OFF for 2 seconds. (It appears as 4 blinks, then OFF for 2 seconds)

CTS and RTS work together for hardware flow control. Configure CP3 as RTS when CP1 is configured as CTS. Select hardware flow control as described in *Flow* in the *XPort User Guide*.

See the *Device Installer User Guide* for information on configuring CP3 as IN3 or OUT3. JP4 can be used to monitor XPort pins 6 (CP1), 7 (CP2), and 8 (CP3). You can also use it to connect external circuitry or LEDs to the evaluation board.

**Figure 3-7. JP4 Configurable Pins Interface Header Footprint**

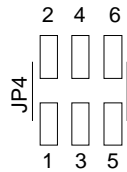

**Table 3-5. JP4 Connections**

JP4 Pin #	Connects To
1	3.3V
2	XPort pin 7, CP2
3	Signal ground
4	XPort pin 6, CP1
5	External reset – XPort pin 3
6	XPort pin 8, CP3

## Timer

The timer circuit is a National LMC555 IC. Its purpose is to generate a timer clock (approximately 10 counts per second). This clock is routed to the input clock pin of the PLD to be used for state machine and counter functions.

## Board Layout

### Component Identification

Figure 3-8. Board Layout

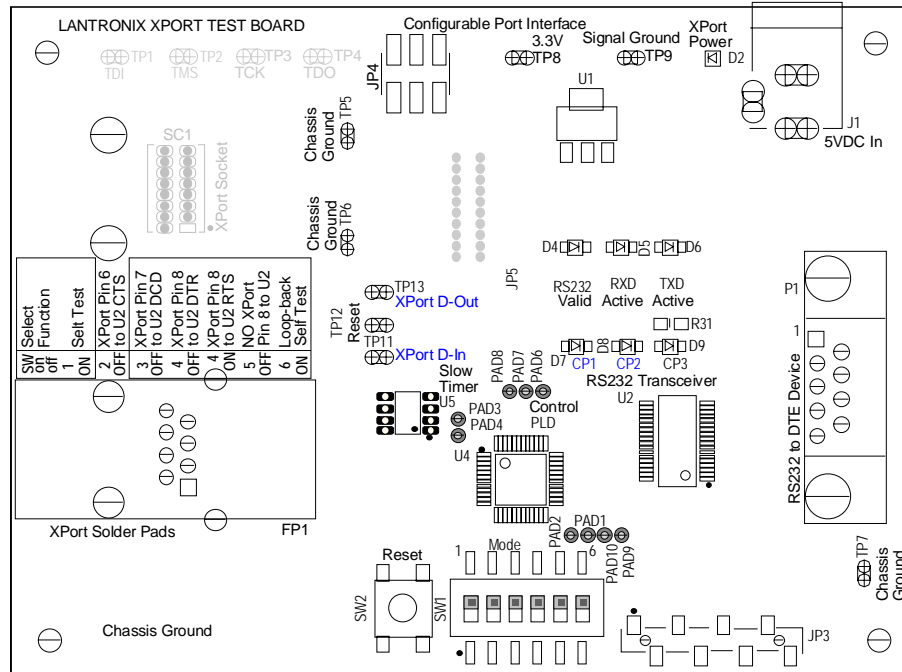
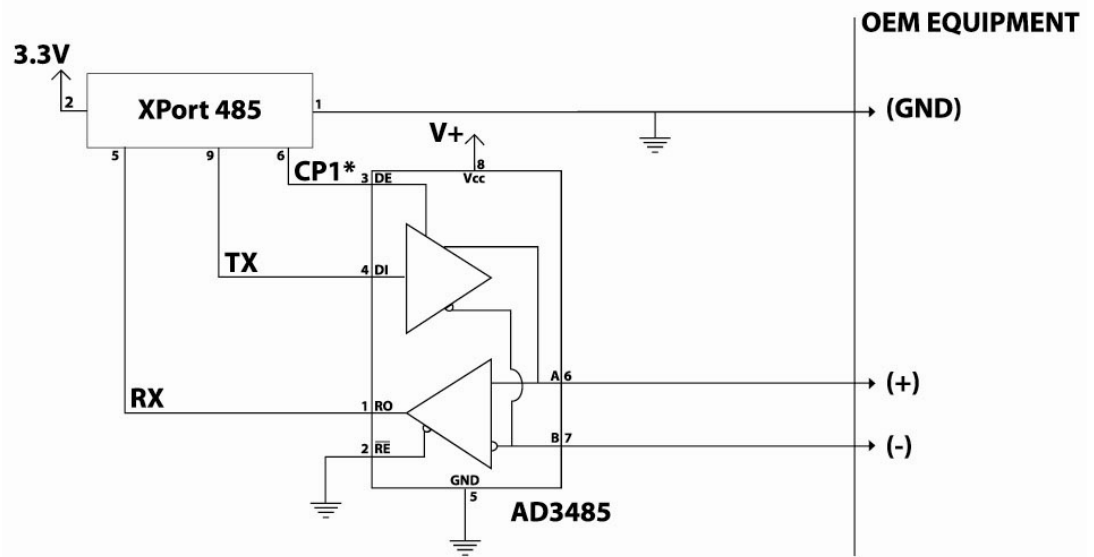

Table 3-6. Board Components

Label	Function	Label	Function
P1	RS-232 interface. DB9F connector	TP1	NA
J1	+5VDC input connector	TP2	NA
SC1	NA	TP3	NA
SW1	Mode switch	TP4	NA
SW2	Reset switch	TP5	Chassis ground
D2	XPort power (red) (LED)	TP6	Chassis ground
D4	RS-232 valid (green) (LED)	TP7	Chassis ground
D5	RXD active (green) (LED)	TP8	XPort 3.3VDC (3V3)
D6	TXD active (green) (LED)	TP9	Signal ground
D7	CP1- XPort pin 6 goes low (LED)		
D8	CP2- XPort pin 7 goes low (LED)	TP11	XPort pin 5, data in
D9	CP3- XPort pin 8 goes low (LED)	TP12	XPort pin 3, reset
JP3	Programming for PLD	TP13	XPort pin 4, data out
JP4	Configurable pins interface header connector	FP1	XPort solder pads
JP5	Factory test – <b>no</b> connector		

## A: XPort-485 Connection Diagram

The following example illustrates a connection between the XPort-485 to an external transceiver IC:



\*Any one of CP1, CP2, or CP3 can be used to control the TX enable.

## ***B: Compliance and Warranty Information***

### **Compliance Information**

(According to ISO/IEC Guide 22 and EN 45014)

#### **Manufacturer's Name & Address:**

Lantronix 15353 Barranca Parkway, Irvine, CA 92618 USA

*Declares that the following product:*

**Product Name Model:** XPort Embedded Device Server

*Conforms to the following standards or other normative documents:*

#### **Electromagnetic Emissions:**

EN55022: 1998 (IEC/CSPIR22: 1993) Radiated RF emissions, 30MHz-1000MHz

Conducted RF Emissions – Telecom Lines – 150 kHz – 30 MHz

FCC Part 15, Subpart B, Class B

IEC 1000-3-2/A14: 2000

IEC 1000-3-3: 1994

#### **Electromagnetic Immunity:**

EN55024: 1998 Information Technology Equipment-Immunity Characteristics

Direct ESD, Contact Discharge

Indirect ESD

Radiated RF Electromagnetic Field Test

Electrical Fast Transient/Burst Immunity

RF Common Mode Conducted Susceptibility

Power Frequency Magnetic Field Test

#### **Manufacturer's Contact:**

Director of Quality Assurance, Lantronix  
15353 Barranca Parkway, Irvine, CA 92618 USA

Tel: 949-453-3990

Fax: 949-453-3995

## Warranty

Lantronix warrants each Lantronix product to be free from defects in material and workmanship for a period of ONE YEAR (-01 models) or TWO YEARS (-03 models). During this period, if a customer is unable to resolve a product problem with Lantronix Technical Support, a Return Material Authorization (RMA) will be issued. Following receipt of a RMA number, the customer shall return the product to Lantronix, freight prepaid. Upon verification of warranty, Lantronix will -- at its option -- repair or replace the product and return it to the customer freight prepaid. If the product is not under warranty, the customer may have Lantronix repair the unit on a fee basis or return it. No services are handled at the customer's site under this warranty. This warranty is voided if the customer uses the product in an unauthorized or improper way, or in an environment for which it was not designed.

Lantronix warrants the media containing its software product to be free from defects and warrants that the software will operate substantially according to Lantronix specifications for a period of 60 DAYS after the date of shipment. The customer will ship defective media to Lantronix. Lantronix will ship the replacement media to the customer.

In no event will Lantronix be responsible to the user in contract, in tort (including negligence), strict liability or otherwise for any special, indirect, incidental or consequential damage or loss of equipment, plant or power system, cost of capital, loss of profits or revenues, cost of replacement power, additional expenses in the use of existing software, hardware, equipment or facilities, or claims against the user by its employees or customers resulting from the use of the information, recommendations, descriptions and safety notations supplied by Lantronix. Lantronix liability is limited (at its election) to:

- ◆ Refund of buyer's purchase price for such affected products (without interest).
- ◆ Repair or replacement of such products, provided that the buyer follows the above procedures.

There are no understandings, agreements, representations or warranties, expressed or implied, including warranties of merchantability or fitness for a particular purpose, other than those specifically set out above or by any existing contract between the parties. Any such contract states the entire obligation of Lantronix. The contents of this document shall not become part of or modify any prior or existing agreement, commitment or relationship.

For details on the Lantronix warranty replacement policy, go to our web site at <http://www.lantronix.com/support/warranty/index.html>.