



10623 Roselle Street, San Diego, CA 92121 • (858) 550-9559 • FAX (858) 550-7322
contactus@accessio.com • www.accessio.com

MODEL PCI-ICM-2S

USER MANUAL

FILE: MPCI-ICM-2S.A1b

Notice

The information in this document is provided for reference only. ACCES does not assume any liability arising out of the application or use of the information or products described herein. This document may contain or reference information and products protected by copyrights or patents and does not convey any license under the patent rights of ACCES, nor the rights of others.

IBM PC, PC/XT, and PC/AT are registered trademarks of the International Business Machines Corporation.

Printed in USA. Copyright 2000, 2005 by ACCES I/O Products Inc, 10623 Roselle Street, San Diego, CA 92121. All rights reserved.

WARNING!!

ALWAYS CONNECT AND DISCONNECT YOUR FIELD CABLING WITH THE COMPUTER POWER OFF. ALWAYS TURN COMPUTER POWER OFF BEFORE INSTALLING A CARD. CONNECTING AND DISCONNECTING CABLES, OR INSTALLING CARDS INTO A SYSTEM WITH THE COMPUTER OR FIELD POWER ON MAY CAUSE DAMAGE TO THE I/O CARD AND WILL VOID ALL WARRANTIES, IMPLIED OR EXPRESSED.

Warranty

Prior to shipment, ACCES equipment is thoroughly inspected and tested to applicable specifications. However, should equipment failure occur, ACCES assures its customers that prompt service and support will be available. All equipment originally manufactured by ACCES which is found to be defective will be repaired or replaced subject to the following considerations.

Terms and Conditions

If a unit is suspected of failure, contact ACCES' Customer Service department. Be prepared to give the unit model number, serial number, and a description of the failure symptom(s). We may suggest some simple tests to confirm the failure. We will assign a Return Material Authorization (RMA) number which must appear on the outer label of the return package. All units/components should be properly packed for handling and returned with freight prepaid to the ACCES designated Service Center, and will be returned to the customer's/user's site freight prepaid and invoiced.

Coverage

First Three Years: Returned unit/part will be repaired and/or replaced at ACCES option with no charge for labor or parts not excluded by warranty. Warranty commences with equipment shipment.

Following Years: Throughout your equipment's lifetime, ACCES stands ready to provide on-site or in-plant service at reasonable rates similar to those of other manufacturers in the industry.

Equipment Not Manufactured by ACCES

Equipment provided but not manufactured by ACCES is warranted and will be repaired according to the terms and conditions of the respective equipment manufacturer's warranty.

General

Under this Warranty, liability of ACCES is limited to replacing, repairing or issuing credit (at ACCES discretion) for any products which are proved to be defective during the warranty period. In no case is ACCES liable for consequential or special damage arriving from use or misuse of our product. The customer is responsible for all charges caused by modifications or additions to ACCES equipment not approved in writing by ACCES or, if in ACCES opinion the equipment has been subjected to abnormal use. "Abnormal use" for purposes of this warranty is defined as any use to which the equipment is exposed other than that use specified or intended as evidenced by purchase or sales representation. Other than the above, no other warranty, expressed or implied, shall apply to any and all such equipment furnished or sold by ACCES.

Table of Contents

Chapter 1: Introduction	5
Figure 1-1: Block Diagram(Only one serial channel shown)	7
Chapter 2: Installation	8
Chapter 3: Option Selection	10
Figure 3-1: Option Selection Map	11
Chapter 4: Address Selection	12
Chapter 5: Programming	13
Table 5-1: Baud Rate Divisor Values	14
Chapter 6: Connector Pin Assignments	17
Table 6-1: Connector Pin Assignments	17
Appendix A: Application Considerations	18
Table A-1: RS422 Specification Summary	18
Figure A-1: Typical RS485 Two-Wire Multidrop Network	19

Chapter 1: Introduction

This Serial Communications Card was designed for use in PCI-Bus computers and provides two serial ports for effective communication in the most common protocols. The card is 6.15 inches long (156 mm) and may be installed in any 5-volt PCI slot in IBM or compatible computers.

Multi-Protocol Operation

These are dual-protocol serial cards that support RS422 and RS485 communications. RS422 uses differential (or balanced) line drivers to improve noise immunity and increase the maximum distance to 4000 feet. RS485 improves on RS422 with switchable transceivers and the ability to support multiple devices on a single "party line". The RS485 specification defines a maximum of 32 devices on a single line. The number of devices served on a single line can be expanded by use of "repeaters".

RS485 and RS422 Balanced Mode Operation

The cards support RS422 and RS485 modes which use differential balanced drivers for increased range and noise immunity. The card also has capability to add bias voltages and to add load resistors to terminate the communications lines. RS485 communications requires that one transmitter supply a bias voltage to ensure a known "zero" state when all transmitters are off. Also, receiver inputs at each end of the network should be terminated to eliminate "ringing". These cards support these options by means of jumpers on the card. See the "Option Selection" section of this manual for more details.

COM Port Compatibility

Type 16550 UARTs are used as the Asynchronous Communication Element (ACE). These include a 16-byte transmit/receive FIFO buffer to protect against lost data in multitasking operating systems, while maintaining 100% compatibility with the original IBM serial port. PCI bus architecture allows addresses between 0000 and FFF8 hex to be assigned to the cards. PCIFind.EXE is a utility provided to determine the base addresses assigned by the system.

A crystal oscillator is located on the card. This oscillator permits selection of baud rates up to 115,200. Rates up to 460,800 baud (4X UART clock) are available by jumper selection.

The driver/receiver used, the 75176, is capable of driving extremely long communication lines at high baud rates. It can drive up to +60 mA on balanced lines and receive inputs as low as 200 mV differential signal superimposed on common mode noise of +12 V or -7 V. In case of communication conflict, the driver/receivers feature thermal shutdown.

Communication Modes

The cards support Half-Duplex, and Full-Duplex communications in 2- and 4-wire cable connections. Half-Duplex allows traffic to travel in both directions, but only one way at a time. In Full-Duplex operation, data travels in both directions at the same time. RS485 communications use the half-duplex mode because only a single pair of wires need to be used and installation costs are dramatically reduced.

RTS and Auto Transceiver Control

In RS485 communications the driver must be enabled and disabled as needed, allowing all cards to share a two wire cable. This card provides automatic control, where the driver is enabled when data is ready to be transmitted. The driver remains enabled for the transmission time of one additional character after data transfer is complete and then is disabled. The cards automatically adjust their timing to the baud rate of the data.

The receiver is also normally disabled during RS485 transmissions.

CE Mark

If your card is CE-marked, it meets the requirements of EN50081-1:1992 (Emissions), EN50082-1:1992 (Immunity), and EN60950:1992 (Safety).

Specification

Communications Interface

- Serial Ports: Shielded male D-sub 9-pin IBM AT style connectors compatible with RS422 and RS485 specifications.
- Character length: 5, 6, 7, or 8 bits.
- Parity: Even, odd or none.
- Stop Interval: 1, 1.5, or 2 bits.
- Serial Data Rates: Up to 115,200 baud, asynchronous. A faster range of rates, up to 460,800 baud, is achieved by jumper selection on the card. Type 16550 buffered UART.

Caution

The OUT2 bit of the UART must be set low for proper interrupt driven communication. This bit enables or disables the interrupts and the card will not communicate if the bit is pulled high.

Differential Communication Mode

- Multipoint: Compatible with RS422 and RS485 specifications. Up to 32 drivers and receivers allowed on line. Serial communications ACE used is type 16550. Driver/Receivers used are type 75176.
- Receiver Input Sensitivity: +200 mV, differential input.
- Common Mode Rejection: +12V to -7V
- Transmitter Output Drive Capability: 60 mA.

Environmental

- Operating Temperature Range: 0 °C. to +60 °C.
- Storage Temperature Range: -50 °C. to +120 °C.
- Humidity: 5% to 95%, non-condensing.
- Power Required: +5VDC at 125 mA typical, +12VDC at 5 mA typical, 685 mW total power consumption.
- Size: 6 1/2" long (165 mm) by 3 7/8" (98 mm).

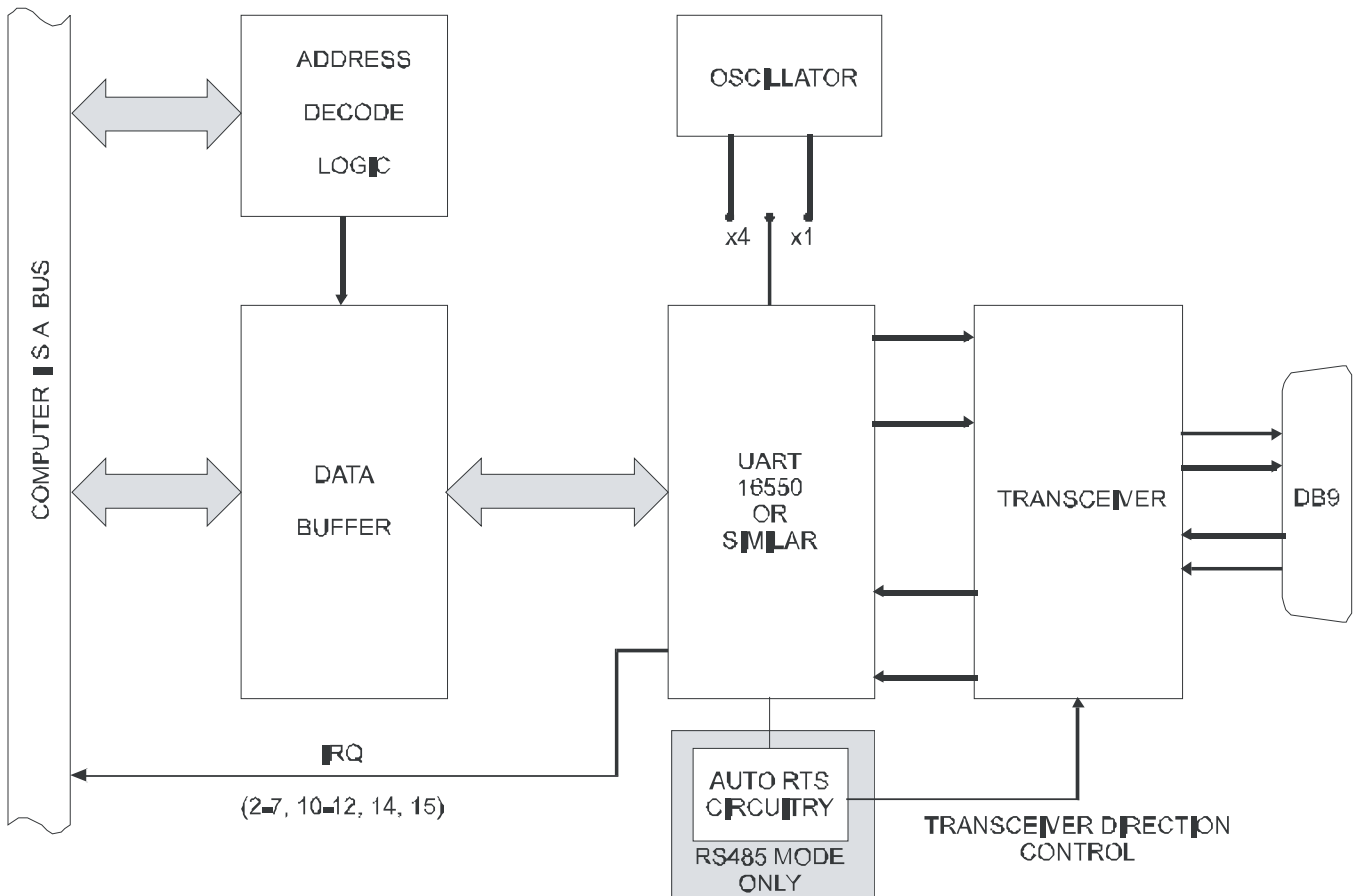

Figure 1-1: Block Diagram(Only one serial channel shown)

Chapter 2: Installation

A printed Quick-Start Guide (QSG) is packed with the card for your convenience. If you've already performed the steps from the QSG, you may find this chapter to be redundant and may skip forward to begin developing your application.

The software provided with this card is on CD and must be installed onto your hard disk prior to use. To do this, perform the following steps as appropriate for your operating system.

Configure Card Options via Jumper Selection

Before installing the card into your computer, carefully read Chapter 3: Option Selection of this manual, then configure the card according to your requirements and protocol (RS-232, RS-422, RS-485, 4-wire 485, etc.). Our Windows based setup program can be used in conjunction with Chapter 3 to assist in configuring jumpers on the card, as well as provide additional descriptions for usage of the various card options (such as termination, bias, baud rate range, RS-232, RS-422, RS-485, etc.).

CD Software Installation

The following instructions assume the CD-ROM drive is drive "D". Please substitute the appropriate drive letter for your system as necessary.

DOS

1. Place the CD into your CD-ROM drive.
2. Type `D: Enter` to change the active drive to the CD-ROM drive.
3. Type `INSTALL Enter` to run the install program.
4. Follow the on-screen prompts to install the software for this board.

WINDOWS

1. Place the CD into your CD-ROM drive.
2. The system should automatically run the install program. If the install program does not run promptly, click START | RUN and type `D:INSTALL`, click OK or press `Enter`.
3. Follow the on-screen prompts to install the software for this board.

LINUX

1. Please refer to linux.htm on the CD-ROM for information on installing under linux.

Note: COM boards can be installed in virtually any operating system. We do support installation in earlier versions of Windows, and are very likely to support future versions as well.

Caution! * ESDA single static discharge can damage your card and cause premature failure! Please follow all reasonable precautions to prevent a static discharge such as grounding yourself by touching any grounded surface *prior to touching the card.*

Hardware Installation

1. Make sure to set switches and jumpers from either the Option Selection section of this manual or from the suggestions of SETUP.EXE.
2. Do not install card into the computer until the software has been fully installed.
3. Turn OFF computer power AND unplug AC power from the system.
4. Remove the computer cover.
5. Carefully install the card in an available 5V or 3.3V PCI expansion slot (you may need to remove a backplate first).
6. Inspect for proper fit of the card and tighten screws. Make sure that the card mounting bracket is properly screwed into place and that there is a positive chassis ground.
7. Install an I/O cable onto the card's bracket mounted connector.
8. Replace the computer cover and turn ON the computer. Enter the CMOS setup program of your system and verify that the PCI plug-and-play option is set appropriately for your system. Systems running Windows 95/98/2000/XP/2003 (or any other PNP-compliant operating system) should set the CMOS option to OS. Systems running under DOS, Windows NT, Windows 3.1, or any other non-PNP-compliant operating system should set the PNP CMOS option to BIOS or Motherboard. Save the option and continue booting the system.
9. Most computers should auto-detect the card (depending on the operating system) and automatically finish installing the drivers.
10. Run PCIfind.exe to complete installing the card into the registry (for Windows only) and to determine the assigned resources.
11. Run one of the provided sample programs that was copied to the newly created card directory (from the CD) to test and validate your installation.

The base address assigned by BIOS or the operating system can change each time new hardware is installed into or removed from the computer. Please recheck PCIFind or Device Manager if the hardware configuration is changed. Software you write can automatically determine the base address of the card using a variety of methods depending on the operating system. In DOS, the PCI\SOURCE directory shows the BIOS calls used to determine the address and IRQ assigned to installed PCI devices. In Windows, the Windows sample programs demonstrate querying the registry entries (created by PCIFind and NTIOPCI.SYS during boot-up) to determine this same information.

Input/Output Connections

Two DB9 connectors are provided on the card mounting bracket for input/output connections. To ensure that there is minimum susceptibility to EMI and minimum radiation, it is important that the card mounting bracket be properly screwed into place and that there be a positive chassis ground. Also, proper EMI cabling techniques (cable connect to chassis ground at the aperture, shielded twisted-pair wiring, etc) be used for the input/output wiring.

Chapter 3: Option Selection

Operation of the serial communications section is determined by jumper installation as described in the following paragraphs. Locations of the jumpers are shown in Figure 3-1, Option Selection at the end of this section of the manual.

422/485

Jumpers must be installed in these blocks for each COM port. The function of the 422 and 485 jumpers is to configure the port for RS-422 or RS-485 mode communications. Either an RS-422 or RS-485 jumper must be used for each channel.

Terminations and Bias

A transmission line should be terminated at the receiving end in its characteristic impedance. Installing a jumper at the location labeled LDO applies a 120Ω load across the output for RS-422 mode and across the transmit/receive input/output for RS-485 operation.

Installing a jumper at the location labeled LDI applies a 120Ω load across the input for RS-422 operation.

The card provides biasing for the RS-485 mode. This biasing is capacitively coupled and is present on all boards.

CLK X1 and CLK X4

Placement of this jumper controls baud rate. CLK X1 permits baud rates up to 115.2K Baud and CLK X4 permits baud rates up to 460.8K Baud.

Data Cable Wiring

When two numbers are joined together with a "&" the two pins are jumpered together.

Mode		Jumpers	Cable	
			Card 1	Card 2
Simplex	2-wire Receive Only	422	Rx+ 9	2
			Rx- 1	3
Simplex	2-wire Transmit Only	422	Tx+ 2	9
			Tx- 3	1
Half-Duplex	2-wire	485	TRx+ 2	2
			TRx- 3	3
Full Duplex	4-wire	422	Tx+ 2	9
			Tx- 3	1
			Rx+ 9	2
			Rx- 1	3

Interrupts

Use PCIFind.EXE to determine the IRQ that was assigned to the card by the BIOS or Operating System. Alternatively, in Windows 9x, the Device Manager can be used. The card's ports are listed under the Ports class. Selecting the port, clicking Properties, then selecting the Resources tab will show the base addresses and IRQ assigned to the port.

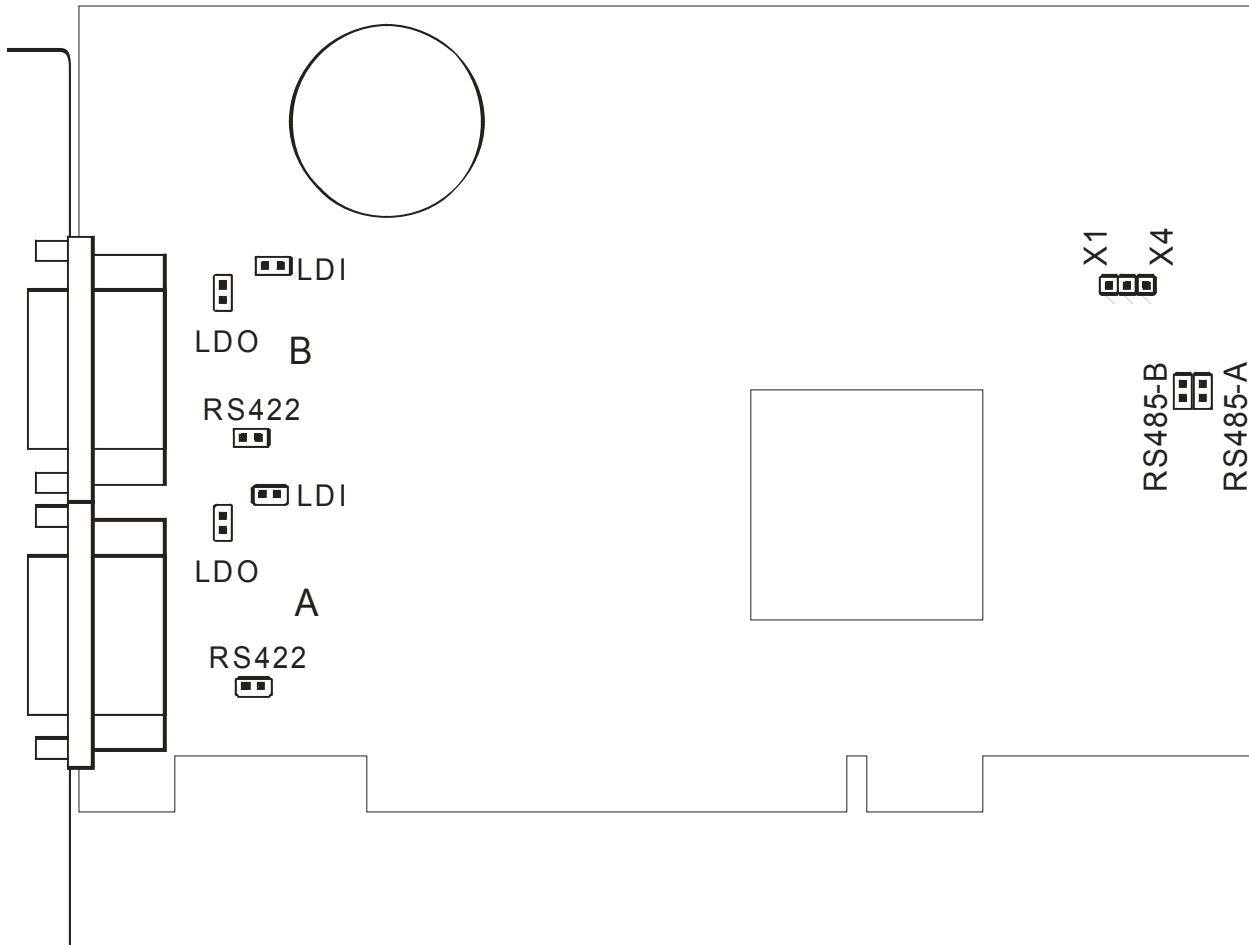

Figure 3-1: Option Selection Map

Jumpers

RS422:	Select differential(RS-422, four-wire) communications mode
RS485-A, RS485-B:	Select differential(RS-485, two-wire) communications mode
LDO:	Apply load to RS-422 or RS-485 output
LDI:	Apply load to RS-422 input
X1/X4:	Select either 115.2 Kbaud or 460.8 Kbaud maximum

Chapter 4: Address Selection

The card uses two separate address spaces, each occupying eight consecutive register locations, for COM A and COM B, respectively. PCI architecture is Plug-and-Play. This means the BIOS or Operating System determines the resources assigned to PCI cards, rather than you selecting these resources with switches or jumpers. As a result, the card's base address cannot be changed, it can only be determined.

To determine the base address that has been assigned to the card, run the provided PCIFind.EXE utility program (PCINT.EXE for Windows95 systems.). This utility will display a list of all of the cards detected on the PCI bus, the addresses assigned to each function on each of the cards, and the respective IRQs and DMAs (if any) allotted.

Alternatively, some operating systems (Windows 95/98/2000) can be queried to determine which resources were assigned. In these operating systems, you can use either PCIFind or the Device Manager utility from the System Properties Applet of the control panel. These cards are installed in the Data Acquisition class of the Device Manager list. Selecting the card then clicking Properties, then selecting the Resources Tab will display a list of the resources allocated to the card.

PCIFind uses the Vendor ID and the device ID to search for your card, then reads the base address and IRQ assigned. If you want to determine the base address and IRQ assigned, use the following information:

The Vendor ID code for this card is 494F (ASCII for "I/O").

The Device ID code for the card is 1150

PCI supports 64 K of address space, so your card's addresses may be located anywhere in the 0000 to FFF8 hex range.

Chapter 5: Programming

Sample Programs

There are sample programs provided with the card in C, Pascal, QuickBASIC, and several Windows languages. DOS samples are located in the DOS directory and Windows samples are located in the WIN32 directory.

Windows Programming

The card installs into Windows as COM ports. Thus the Windows standard API functions can be used. In particular:

- ▶ CreateFile() and CloseHandle() for opening and closing a port.
- ▶ SetupComm(), SetCommTimeouts(), GetCommState(), and SetCommState() to set and change a port's settings.
- ▶ ReadFile() and WriteFile() for accessing a port.

See the documentation for your chosen language for details.

Under DOS, the process is very different. The remainder of this chapter describes DOS programming.

Initialization

Initializing the chip requires knowledge of the UART's register set. The first step is to set the baud rate divisor. You do this by first setting the DLAB (Divisor Latch Access Bit) high. This bit is Bit 7 at Base Address +3. In C code, the call would be:

```
outportb(BASEADDR +3,0x80);
```

You then load the divisor into Base Address +0 (low byte) and Base Address +1 (high byte). The following equation defines the relationship between baud rate and divisor:

$$\text{Desired Baud Rate} = (\text{UART clock frequency}) \div (32 \text{ divisor})$$

When the BAUD jumper is in the X1 position, the UART clock frequency is 1.8432MHz. When the jumper is in the X4 position, the clock frequency is 7.3728 MHz. The following table lists popular divisor frequencies. Note that there are two columns to consider depending on the position of the BAUD jumper.

Baud Rate	Divisor x1	Divisor x4	Max Diff. Cable Length*
460800	-	1	550 ft
230400	-	2	1400 ft
153600	-	3	2500 ft
115200	1	4	3000 ft
57600	2	8	4000 ft
38400	3	12	4000 ft
28800	4	16	4000 ft
19200	6	24	4000 ft
14400	8	32	4000 ft
9600	12	48 – Most Common	4000 ft
4800	24	96	4000 ft
2400	48	192	4000 ft
1200	96	384	4000 ft

* Recommended maximum distances for differentially driven data cables (RS422 or RS485) are for typical conditions.

Table 5-1: Baud Rate Divisor Values

In C, the code to set the chip to 9600 baud is:

```
outputb(BASEADDR, 0x0C);
outputb(BASEADDR +1,0);
```

The second initializing step is to set the Line Control Register at Base Address +3. This register defines word length, stop bits, parity, and the DLAB.

Bits 0 and 1 control word length and allow word lengths from 5 to 8 bits. Bit settings are extracted by subtracting 5 from the desired word length.

Bit 2 determines the number of stop bits. There can be either one or two stop bits. If Bit 2 is set to 0, there will be one stop bit. If Bit 2 is set to 1, there will be two stop bits.

Bits 3 through 6 control parity and break enable. They are not commonly used for communications and should be set to zeroes.

Bit 7 is the DLAB discussed earlier. It must be set to zero after the divisor is loaded or else there will be no communications.

The C command to set the UART for an 8-bit word, no parity, and one stop bit is:

```
outputb(BASEADDR +3, 0x03)
```

The third step of the initialization sequence is to set the Modem Control Register at Base Address +4. Bit 1 is the Request to Send (RTS) control bit. This bit should be left low until transmission time. (Note: When operating in the automatic RS485 mode, the state of this bit is not significant.) Bits 2 and 3 are user-designated outputs. Bit 2 may be ignored on this card. Bit 3 is used to enable interrupts and should be set high if an interrupt-driven receiver is to be used.

The final initialization step is to flush the receiver buffers. You do this with two reads from the receiver buffer at Base Address +0. When done, the UART is ready to use.

Reception

Reception can be handled in two ways: polling and interrupt-driven. When polling, reception is accomplished by constantly reading the Line Status Register at Base Address +5. Bit 0 of this register is set high whenever data are ready to be read from the chip. A simple polling loop must continuously check this bit and read in data as it becomes available. The following code fragment implements a polling loop and uses a value of 13, (ASCII Carriage Return) as an end-of-transmission marker:

```
do{
    while (!(inportb(BASEADDR +5) & 1)); /*Wait until data ready*/
    data[i++] = inportb(BASEADDR);
}while (data[i] != 13); /*Reads the line until null character
                        rec'd*/
```

Interrupt-driven communications should be used whenever possible and is required for high data rates. Writing an interrupt-driven receiver is not much more complex than writing a polled receiver but care should be taken when installing or removing your interrupt handler to avoid writing the wrong interrupt, disabling the wrong interrupt, or turning interrupts off for too long a period.

The handler would first read the Interrupt Identification Register at Base Address +2. If the interrupt is for Received Data Available, the handler then reads the data. If no interrupt is pending, control exits the routine. A sample handler, written in C, is as follows:

```
readback = inportb(BASEADDR +2);
if(readback & 4) /*Readback will be set to 4 if data are available*/
data[i++] = inportb(BASEADDR);
outportb(0x20,0x20); /*Write EOI to 8259 Interrupt Controller*/
return;
```

Transmission

The Auto feature of the card automatically enables the transmitter when data are ready to send so no software enabling is required. The following software example is for non-Auto operation.

First the RTS line should be set high by writing a 1 to Bit 1 of the Modem Control Register at Base Address +4. The RTS line is used to toggle the transceiver from receive mode to transmit mode and vice versa. It is not carried out on the line in RS485 and is not used for handshaking. Similarly, the CTS line is not used in RS485 and should always be enabled by installing a jumper as described earlier.

After the above is done, the card is ready to send data. To transmit a string of data, the transmitter must first check Bit 5 of the Line Status Register at Base Address +5. That bit is the transmitter-holding-register-empty flag. If it is high, the transmitter has sent the data. The process of checking the bit until it goes high followed by a write is repeated until no data remains. After all data has been transmitted, the RTS bit should be reset by writing a 0 to Bit 1 of the Modem Control Register.

The following C code fragment demonstrates this process:

```
outportb(BASEADDR +4, inportb(BASEADDR +4)|0x02);
/*Set RTS bit without altering states of other bits*/
while(data[i]); /*While there is data to send*/
{
while(!(inportb(BASEADDR +5)&0x20)); /*Wait until transmitter is empty*/
outportb(BASEADDR,data[i]);
i++;
}
outportb(BASEADDR +4, inportb(BASEADDR +4)&0xFD);
/*Reset RTS bit without altering states of other bits*/
```

Caution

The OUT2 bit of the UART must be set low for proper interrupt driven communication. This bit enables or disables the interrupts and the card will not communicate if the bit is pulled high.

Chapter 6: Connector Pin Assignments

The popular 9-pin D subminiature connector is used for interfacing to communication lines. The connector is equipped with 4-40 threaded standoffs (female screw lock) to provide strain relief.

Pin No.	RS422 Functions	RS485 Functions
1	Rx- Receive Data	
2	Tx+ Transmit Data	TRx+ Transmit/Receive Data
3	Tx- Transmit Data	TRx- Transmit/Receive Data
4		
5	GND Ground	GND Ground
6		
7		
8		
9	Rx+ Receive Data	

Table 6-1: Connector Pin Assignments

Note

If connections are to be made to a CE-marked version, then CE-certifiable cabling and breakout methodology (Cable shields connected to ground at the mounting bracket shielded twisted-pair wiring, etc) must be used.

Appendix A: Application Considerations

Balanced Differential Signals

The reason that RS422 and RS485 devices can drive long lines with more noise immunity is that a balanced differential drive method is used. In a balanced differential system, the voltage produced by the driver appears across a pair of wires. A balanced line driver will produce a differential voltage from +2 to +6 volts across its output terminals. A balanced line driver can also have an input "enable" signal that connects the driver to its output terminals. If the "enable" signal is OFF, the driver is disconnected from the transmission line. This disconnected or disabled condition is usually referred to as the "tristate" condition and represents a high impedance. RS485 drivers must have this control capability. RS422 drivers may have this control but it is not always required.

A balanced differential line receiver senses the voltage state of the transmission line across the two signal input lines. If the differential input voltage is greater than +200 mV, the receiver will provide a specific logic state on its output. If the differential voltage input is less than -200 mV, the receiver will provide the opposite logic state on its output. The maximum operating voltage range is from +6V to -6V allowing for voltage attenuation that can occur on long transmission cables.

A maximum common mode voltage rating of +7V provides good noise immunity from voltages induced on the twisted pair lines. The signal ground line connection is necessary in order to keep the common mode voltage within that range. The circuit may operate without the ground connection but may not be reliable.

Parameter	Conditions	Min.	Max.
Driver Output Voltage (unloaded)		4V	6V
		-4V	-6V
Driver Output Voltage (loaded)	LDO	2V	
	jumpers in	-2V	
Driver Output Resistance			50Ω
Driver Output Short-Circuit Current			+150 mA
Driver Output Rise Time			10% unit interval
Receiver Sensitivity			+200 mV
Receiver Common Mode Voltage Range			+7V
Receiver Input Resistance			4KΩ

Table A-1: RS422 Specification Summary

To prevent signal reflections in the cable and to improve noise rejection in both the RS422 and RS485 mode, the receiver end of the cable should be terminated with a resistance equal to the characteristic impedance of the cable. (The exception is when the line is driven by an RS422 driver that is never "tristated" or disconnected from the line. In this case, the driver provides a low internal impedance that terminates the line at that end.)

Note

You do not have to add a terminator resistor to your cables when you use the PCI-ICM-2S card. Termination resistors for the RX+ and RX- lines are provided on the card and are placed in the circuit when you install the termination jumpers. Moreover, installing the BIAS jumpers properly biases these lines. (See the Option Selection section of this manual.)

RS485 Data Transmission

The RS485 Standard allows a balanced transmission line to be shared in a party-line mode. As many as 32 driver/receiver pairs can share a two-wire party line network. Many characteristics of the drivers and receivers are the same as in the RS422 Standard. One difference is that the common mode voltage limit is extended and is +12V to -7V. Since any driver can be disconnected (or tristated) from the line, it must withstand this common mode voltage range while in the tristate condition.

RS485 Two-Wire Multidrop Network

The following illustration shows a typical multidrop or party line network. Note that the transmission line is terminated on both ends of the line but not at drop points in the middle of the line.

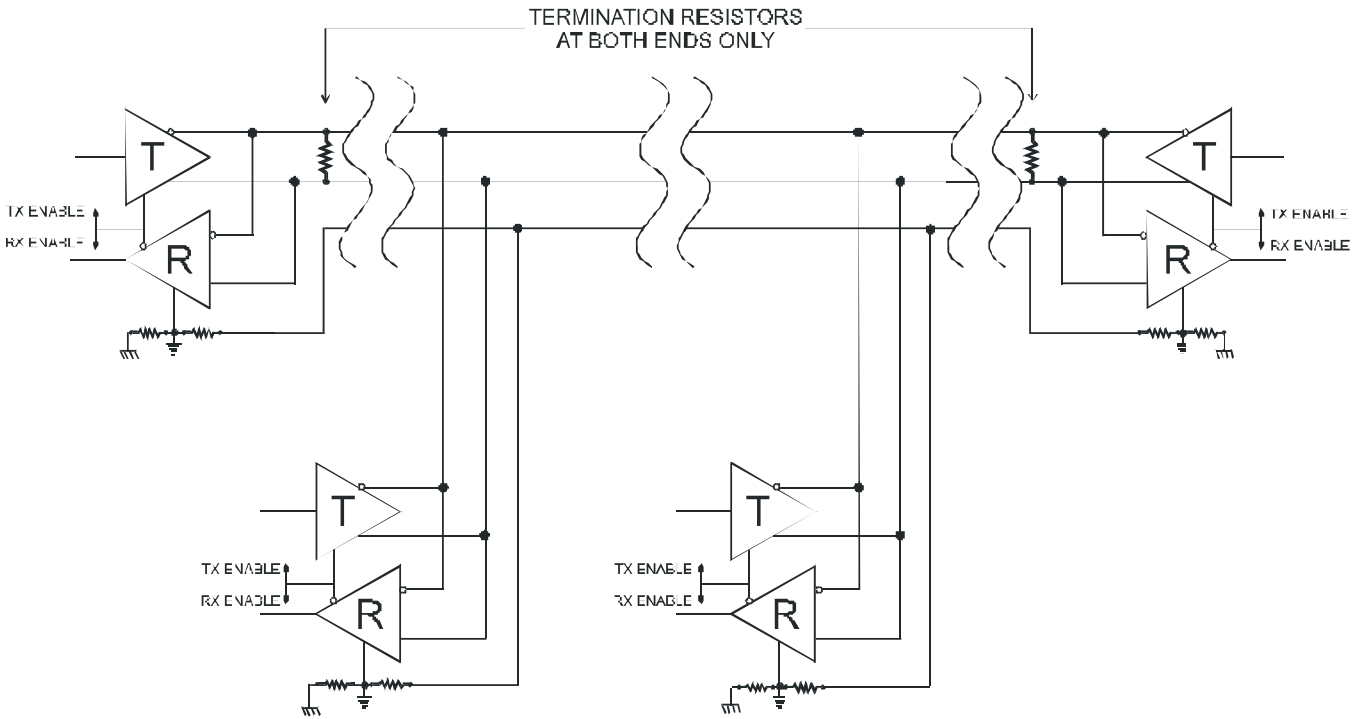

Figure A-1: Typical RS485 Two-Wire Multidrop Network

RS485 Four-Wire Multidrop Network

An RS485 network can also be connected in a four-wire mode. In a four-wire network it's necessary that one node be a master node and all others be slaves. The network is connected so that the master communicates to all slaves and all slaves communicate only with the master. This has advantages in equipment that uses mixed protocol communications. Since the slave nodes never listen to another slave's response to the master, a slave node cannot reply incorrectly.

Customer Comments

If you experience any problems with this manual or just want to give us some feedback, please email us at: ***manuals@acesio.com***. Please detail any errors you find and include your mailing address so that we can send you any manual updates.



10623 Roselle Street, San Diego CA 92121
Tel. (858)550-9559 FAX (858)550-7322
www.acesio.com